

High Reliability Connectors

Microminiature MDM Connectors

High performance Microminiature connectors, ESA qualified, for space applications.

Suitable for Board-to Board, Board-to Cable or Cable-to Cable applications.

Space/High reliability MDM connectors meet stringent tests for outgassing and residual magnetism and are suitable for use in space, medical, and high performance military/aerospace applications.

MDM connectors meet the performance of the ESCC 3401 and MIL-PRF-83513 Specifications and the dimensional requirements of the ESCC 3401/031 Detail Specification.

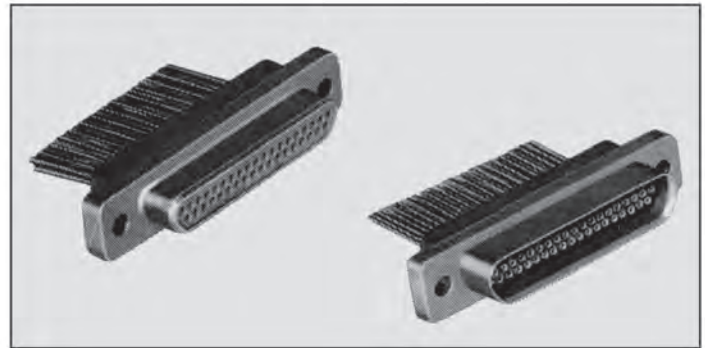

Product Features

- ◆ High performance Micropin™ contact system ("twist pin" spring male contact and tubular socket contact)
- ◆ Non removable crimp type contacts
- ◆ The Connectors are supplied with the Terminations or Cables installed in factory
- ◆ MDM Connector layout : 9, 15, 21, 25, 31, 37, 51 cavities
- ◆ MDM contact centers : 1,27 (.050)
- ◆ Distance between :
 - 2 adjacent contacts : 1,27 (.050)
 - 2 contact rows : 1,09 (.043)
- ◆ Non-magnetic
- ◆ Non-outgassing
- ◆ Moisture and humidity seal between contacts and between contacts and shell, provided by compression interfacial seal

Materials and Finishes

Shells	Aluminium alloy Finish A174 : 25,4 µm min. (1000 µin min.) electroless Nickel over Copper underlay Finish FR172 : 2,54 µm min. (100 µin min.) Gold over 25,4 µm min. (1000 µin min.) electroless Nickel
Insulators	LCP (Liquid Crystal Polymer) thermoplastic material, UL 94-V0, glass-filled, black color
Female contacts	Copper alloy / Finish : 1,27 µm (50 µin) min. Gold over Copper underlay
Male contacts	Copper alloy / Finish : 1,27 µm (50 µin) min. Gold over Copper underlay
MDM PCB Housings	Diallylphtalate thermoset material, UL 94-VO, glass-filled, dark green color
Interfacial Seals	Fluorosilicone elastomere, pink color
Screwlocks	Stainless Steel type 303, passivated
Accessories	Stainless Steel type 303, passivated
Dust Caps	Polyethylene thermoplastic material, transparent pink color
Encapsulant	Epoxy
Uninsulated rigid Wire	Copper / Finish : 1,27 µm (50 µin) min. Gold over 2,54 (100 µin) min. Silver underlay
ESCC 3901/013 Cables	Copper alloy / Finish 2,00 µm (79 µin) min. Silver / Extruded PTFE Insulation
ESCC 3901/002 Cables	Copper alloy / Finish 2,00 µm (79 µin) min. Silver / Wrapped Polyimide tape Insulation
MIL-W-16878/4 Cables	Copper alloy / Finish Silver coating / Extruded PTFE Insulation

Quality Levels

ESA Quality Level.

The Dole plant (France) is qualified by ESA for the supply of Microminiature connectors Type MDM, according to the ESCC Generic Specification N° 3401, and to the applicable ESCC Detail Specifications n° 3401/029 (MDM Connectors), 3401/041 (Connector Savers) and 3401/032 (Accessories).

First qualification obtained in 1986 (renewed every 2 years).

Qualification certificate : 140 (MDM).

Applications : Flight equipments, satellites, launchers (ESA requirements).

FR022 Quality Level.

“Commercial Space Grade”.

C&K Connector Specification CS FR022, amendment to the ESCC Generic Specification n° 3401, for low cost products manufactured :

- in the same ESA qualified site
- through the same manufacturing and control processes
- with the same piece parts (except for the cables : MIL-W-16878/4 instead of ESCC 3901)
- with lighter controls, documentation and traceability

Applications : Engineering models, ground equipments, testing, some flight equipments (no need for high requirements).

The connectors and accessories, supplied according to these 2 quality levels, are totally compatible, interchangeable, and intermateable, as they are manufactured with the same piece parts (except for the cables), in the same ESA qualified site.

Performance Specifications

Operating Temperature range	-55°C / +125°C (-67°F / +257°F)					
Storage Temperature range	-55°C / +125°C (-67°F / +257°F)					
Working Voltage (between contacts and contact and shell)	Sea level	33000 m (108240 feet) altitude				
	150 Vrms	100 Vrms				
Rated Current	Solid uninsulated Wire	AWG 26 Wire	AWG 28 Wire			
	2,5 A max.	2,5 A max.	1,5 A max.			
Insulation Resistance (500 V DC)	5000 MΩ min.					
Voltage Proof	600 Vrms / 2.0 mA max. leakage current					
Contact Retention in insert	22,25 N max. / No contact axial displacement allowed					
Engagement / Separation Forces (Male Contacts)	Gauge Fixture	Inner diameter min. / max.	Separation Force (N min.)		Engagement Force (N max.)	
	Max.	0,559 (.0220) / 0,564 (.0222)			1,667	
	Min.	0,582 (.0229) / 0,587 (.0231)	0,137			
Mating / Unmating Forces	Shell Size max.)	Mating Force (N max.)	Unmating Force (N min.)		Unmating Force (N max.)	
	9	20	1.3		20	
	15	33	2.0		33	
	21	47	2.9		47	
	25	55	3.5		55	
	31	69	4.3		69	
	37	82	5.1		82	
	51	113	7.1		113	
	100	222	-		222	
Mechanical Endurance	500 cycles mating/unmating					
Contact Resistance	Low level current (10 mA / 20 mV DC) : 6.0 mΩ max. Rated current : 5.0 mΩ max.					
Maximum Rated Current	Nb of Contacts per Connector	Solid uninsulated Wire	AWG 26 Wire	AWG 28 Wire		
	2 to 4	2,0 A max.	2,0 A max.	1,4 A max.		
	5 to 14	1,8 A max.	1,8 A max.	1,2 A max.		
	15 and over	1,4 A max.	1,4 A max.	0,9 A max.		
Maximum Weight	Shell Size	FR112 to FR116 & FR123 (1)	FR136 (2)	FR136A (2)	FR139 (2)	Savers (2)
	9	2.2 g	7.4 g	7.4 g	4.6 g	4.0 g
	15	3.0 g	7.8 g	N.A.	5.0 g	5.5 g
	21	3.8 g	8.5 g	N.A.	5.4 g	7.0 g
	25	4.3 g	10.2 g	N.A.	6.5 g	8.0 g
	31	5.1 g	12.2 g	N.A.	7.7 g	9.5 g
	37	5.9 g	14.4 g	N.A.	9.2 g	10.0 g
	51	7.2 g	16.5 g	N.A.	N.A.	13.5 g
Note (1) : Connector with contacts and rear potting, without cables and accessories Add : 0.4 g for float mount (code F) Add : 1.0 g for captive nut (code E)						
Note (2) : Connectors with contacts and rear potting						
Solid Uninsulated Wire		1.60 g / m				
Insulated Cable AWG26 (ESCC 390101302B)		2.30 g / m				
Insulated Cable AWG28 (ESCC 390101301B)		1.80 g / m				
Insulated Cable AWG26 (ESCC 390100256B)		1.93 g / m				
Insulated Cable AWG28 (ESCC 390100261B)		1.23 g / m				
Hardwares : see pages 31 to 38						
Residual Magnetism Level	20000 Gamma max. (NM)					

MDM

Contact Design

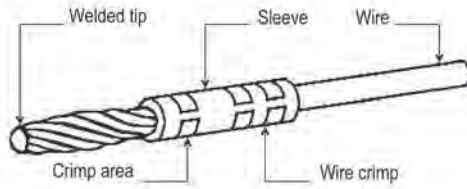

The high-performance and reliable contact characteristics are obtained by the Micropin™ contact system. The flexible “twist-pin” spring contact consists of 7 strands of 0,127 (.005) diameter beryllium copper wire helically wound around a core of 3 strands 0,09 (.0035) diameter soft copper wire. This wire bundle is crimped into a sleeve at one end. The other end is terminated with a hemispherically shaped weld. The wire bundle is compressed to create a bulge with a diameter slightly larger than the socket inside diameter. The pin elongates and twists when it enters the socket. Electrical contact is maintained along 7 spiral lines. The socket is a precision-made tube with a chamfered lead-in.



Normal mating conditions

Severe misalignment

Twist-pin contacts will mate even under severe misalignment.

The flexible twist-pin is recessed into the insulator and the rigid socket is exposed, reversing the traditional positions of pin and socket. During mating, the socket is guided into the pin insulator by the lead-in chamfer. The pin is kept from flexing beyond the socket capture radius by the walls of the cavity. The hemispherical weld of controlled radius at the tip of the pin combines with the lead-in chamfers of the socket contact and the pin insulator to cam the pin into alignment. By controlling the welding process and the dimensions of the socket contact and the insulators, it is impossible for the recessed pin to escape the socket capture radius.

MDM

Dimensions

Shell Size (Plug)

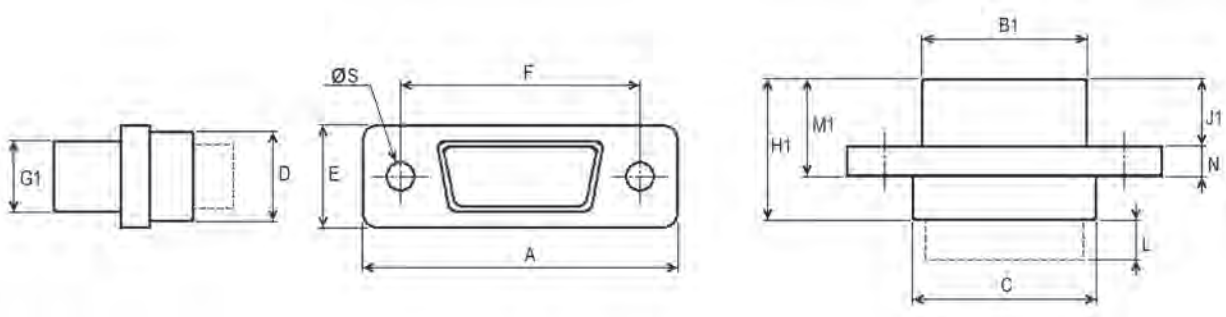

Shell Size (Receptacle)

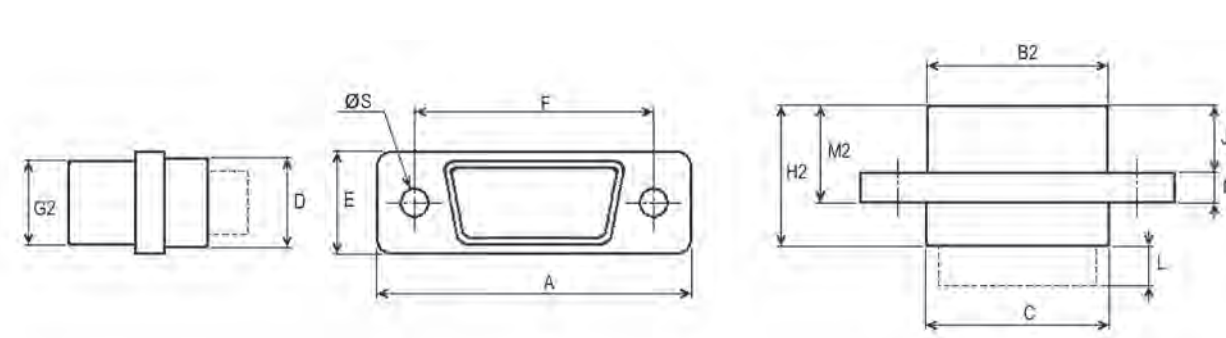

Shell Size		9	15	21	25	31	37	51
A	max.	19,94 (.785)	23,75 (.935)	27,56 (1.085)	30,10 (1.185)	33,91 (1.335)	37,72 (1.485)	36,45 (1.435)
B1	max.	8,46 (.333)	12,27 (.483)	16,08 (.633)	18,62 (.733)	22,43 (.883)	26,24 (1.033)	24,97 (.983)
B2	max.	10,16 (.400)	13,97 (.550)	17,78 (.700)	20,32 (.800)	24,13 (.950)	27,94 (1.100)	26,67 (1.050)
C	max.	10,16 (.400)	13,97 (.550)	17,78 (.700)	20,32 (.800)	24,13 (.950)	27,94 (1.100)	26,67 (1.050)
D	max.	6,86 (.270)	6,86 (.270)	6,86 (.270)	6,86 (.270)	6,86 (.270)	6,86 (.270)	7,87 (.310)
E	max.	7,82 (.308)	7,82 (.308)	7,82 (.308)	7,82 (.308)	7,82 (.308)	7,82 (.308)	8,92 (.351)
F	± 0,13 (.005)	14,35 (.565)	18,16 (.715)	21,97 (.865)	24,51 (.965)	28,32 (1.115)	32,13 (1.265)	30,86 (1.215)
G1	max.	4,65 (.184)	4,65 (.184)	4,65 (.184)	4,65 (.184)	4,65 (.184)	4,65 (.184)	5,74 (.227)
G2	max.	6,38 (.252)	6,38 (.252)	6,38 (.252)	6,38 (.252)	6,38 (.252)	6,38 (.252)	7,47 (.295)
H1	max.	10,57 (.416)	10,57 (.416)	10,57 (.416)	10,57 (.416)	10,57 (.416)	10,57 (.416)	10,57 (.416)
H2	max.	10,90 (.429)	10,90 (.429)	10,90 (.429)	10,90 (.429)	10,90 (.429)	10,90 (.429)	10,90 (.429)
J1	max.	4,72 (.186)	4,72 (.186)	4,72 (.186)	4,72 (.186)	4,72 (.186)	4,72 (.186)	4,72 (.186)
J2	max.	5,05 (.199)	5,05 (.199)	5,05 (.199)	5,05 (.199)	5,05 (.199)	5,05 (.199)	5,05 (.199)
L	max.	Termination Length : see page 8						
M1	max.	7,26 (.286)	7,26 (.286)	7,26 (.286)	7,26 (.286)	7,26 (.286)	7,26 (.286)	7,26 (.286)
M2	max.	7,59 (.299)	7,59 (.299)	7,59 (.299)	7,59 (.299)	7,59 (.299)	7,59 (.299)	7,59 (.299)
N	± 0,13 (.005)	2,29 (.090)	2,29 (.090)	2,29 (.090)	2,29 (.090)	2,29 (.090)	2,29 (.090)	2,29 (.090)
Øs	± 0,08 (.003)	2,31 (.091)	2,31 (.091)	2,31 (.091)	2,31 (.091)	2,31 (.091)	2,31 (.091)	2,31 (.091)

MDM

Terminations

Code	Quality Level	Dimensions and composition of the Terminations or Cables							
		AWG	Length	Strands	Sheath	Conductor dia.	Conductor sect.	Sheath dia.	Cable Ref.
FR112 FR112A H038	ESA ESA FR022	26	508,00 min. (20.000 min.)	7 19 7	PTFE Polyimide PTFE	0,50 mm max. 0,53 mm max. 0,48 mm max.	0,14 mm ² nom. 0,15 mm ² nom. 0,14 mm ² nom.	0,89 mm max. 0,78 mm max. 1,10 mm max.	ESCC 390101302 ESCC 390100256 MIL-W-16878/4
FR113 FR113A H011	ESA ESA FR022	26	914,00 min. (36.000 min.)	7 19 7	PTFE Polyimide PTFE	0,50 mm max. 0,53 mm max. 0,48 mm max.	0,14 mm ² nom. 0,15 mm ² nom. 0,14 mm ² nom.	0,89 mm max. 0,78 mm max. 1,10 mm max.	ESCC 390101302 ESCC 390100256 MIL-W-16878/4
FR123 FR123A CDRI (*)	ESA ESA FR022	26	4000,00 min. (1 5 7 . 4 8 0 min.)	7 19 7	PTFE Polyimide PTFE	0,50 mm max. 0,53 mm max. 0,48 mm max.	0,14 mm ² nom. 0,15 mm ² nom. 0,14 mm ² nom.	0,89 mm max. 0,78 mm max. 1,10 mm max.	ESCC 390101302 ESCC 390100256 MIL-W-16878/4
FR114 FR114A H038- AWG28	ESA ESA FR022	28	508,00 min. (20.000 min.)	7 19 7	PTFE Polyimide PTFE	0,42 mm max. 0,43 mm max. 0,39 mm max.	0,09 mm ² nom. 0,10 mm ² nom. 0,09 mm ² nom.	0,82 mm max. 0,68 mm max. 1,00 mm max.	ESCC 390101301 ESCC 390100261 MIL-W-16878/4
FR115 FR115A H011- AWG28	ESA ESA FR022	28	914,00 min. (36.000 min.)	7 19 7	PTFE Polyimide PTFE	0,42 mm max. 0,43 mm max. 0,39 mm max.	0,09 mm ² nom. 0,10 mm ² nom. 0,09 mm ² nom.	0,82 mm max. 0,68 mm max. 1,00 mm max.	ESCC 390101301 ESCC 390100261 MIL-W-16878/4
FR116 L2	ESA FR022	25	25,40 min. (1.000 min.)	Solid uninsulated wire (Gold finish)		0,455mm max.	0,162 mm ² nom.	Straight Pigtail Terminations	
FR136 FR136	ESA FR022	25	4,50 ± 0,35 (.177 ± .014)	Solid uninsulated wire (Gold finish)		0,455mm max.	0,162 mm ² nom.	90° bent PCB Terminations (Sizes 9 to 51)	
FR136A FR136A	ESA FR022	25	3,50 ± 0,20 (.138 ± .008)	Solid uninsulated wire (Gold finish)		0,455mm max.	0,162 mm ² nom.	90° bent PCB Terminations (Size 9 / Narrow profile)	
FR139 FR139	ESA FR022	25	4,50 ± 0,35 (.177 ± .014)	Solid uninsulated wire (Gold finish)		0,455mm max.	0,162 mm ² nom.	Straight PCB Terminations (Size 9 to 37)	

Other termination types available on request : CDRI (*)

Availability per
Shell Size

Shell Size	9	15	21	25	31	37	51
FR112 + ...	Yes	Yes	Yes	Yes	Yes	Yes	Yes
FR113 + ...	Yes	Yes	Yes	Yes	Yes	Yes	Yes
FR123 + ...	Yes	Yes	Yes	Yes	Yes	Yes	Yes
FR114 + ...	Yes	Yes	Yes	Yes	Yes	Yes	Yes
FR115 + ...	Yes	Yes	Yes	Yes	Yes	Yes	Yes
FR116 + ...	Yes	Yes	Yes	Yes	Yes	Yes	Yes
FR136	Yes	Yes	Yes	Yes	Yes	Yes	Yes
FR136A	Yes	N.A.	N.A.	N.A.	N.A.	N.A.	N.A.
FR139	Yes	Yes	Yes	Yes	Yes	Yes	N.A.

Connector Type FR136 / 90° bent PCB Terminations (Shell Sizes 9 to 37)

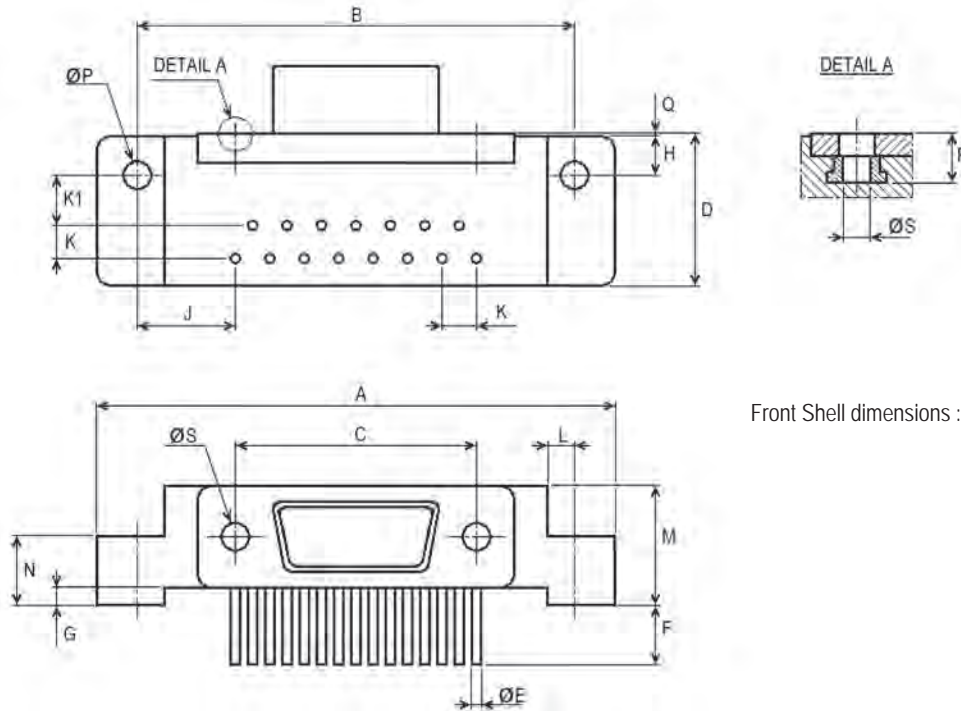

Front Shell dimensions : see page 93

Shell Size		9	15	21	25	31	37
A	max.	35,31 (1.390)	39,12 (1.540)	42,93 (1.690)	45,47 (1.790)	51,82 (2.040)	59,44 (2.340)
B	± 0,18 (.007)	29,21 (1.150)	33,02 (1.300)	36,83 (1.450)	39,37 (1.550)	F 45,72 (1.800)	53,34 (2.100)
C	± 0,13 (.005)	14,35 (.565)	18,16 (.715)	21,97 (.865)	24,51 (.965)	28,32 (1.115)	32,13 (1.265)
D	max.	11,56 (.455)	11,56 (.455)	11,56 (.455)	11,56 (.455)	11,56 (.455)	11,56 (.455)
øE	max.	0,46 (.018)	0,46 (.018)	0,46 (.018)	0,46 (.018)	0,46 (.018)	0,46 (.018)
F	± 0,35 (.014)	4,50 (.177)	4,50 (.177)	4,50 (.177)	4,50 (.177)	4,50 (.177)	4,50 (.177)
G	± 0,20 (.008)	1,50 (.059)	1,50 (.059)	1,50 (.059)	1,50 (.059)	1,50 (.059)	1,50 (.059)
H	± 0,38 (.015)	3,17 (.125)	3,17 (.125)	3,17 (.125)	3,17 (.125)	3,17 (.125)	3,17 (.125)
J	Typ.	9,53 (.375)	7,62 (.300)	5,72 (.225)	4,45 (.175)	3,81 (.150)	3,81 (.150)
K	Typ.	2,54 (.100)	2,54 (.100)	2,54 (.100)	2,54 (.100)	2,54 (.100)	2,54 (.100)
K1	± 0,25 (.010)	3,81 (.150)	3,81 (.150)	3,81 (.150)	3,81 (.150)	3,81 (.150)	3,81 (.150)
L	± 0,05 (.002)	2,05 (.081)	2,05 (.081)	2,05 (.081)	2,05 (.081)	2,05 (.081)	2,05 (.081)
M	± 0,10 (.004)	9,10 (.358)	9,10 (.358)	9,10 (.358)	9,10 (.358)	9,10 (.358)	9,10 (.358)
N	± 0,15 (.006)	5,30 (.209)	5,30 (.209)	5,30 (.209)	5,30 (.209)	5,30 (.209)	5,30 (.209)
øP (*)	± 0,15 (.006)	2,45 (.096)	2,45 (.096)	2,45 (.096)	2,45 (.096)	2,45 (.096)	2,45 (.096)
Q	± 0,10 (.004)	0,30 (.012)	0,30 (.012)	0,30 (.012)	0,30 (.012)	0,30 (.012)	0,30 (.012)
R	min.	4,60 (.181)	4,60 (.181)	4,60 (.181)	4,60 (.181)	4,60 (.181)	4,60 (.181)
øS	Typ.	2-56-UNC-2B	2-56-UNC-2B	2-56-UNC-2B	2-56-UNC-2B	2-56-UNC-2B	2-56-UNC-2B

Note (*) : Maximum torque 0.44 Nm.

Connector Type FR136 / 90° bent PCB Terminations (Shell Size 51)

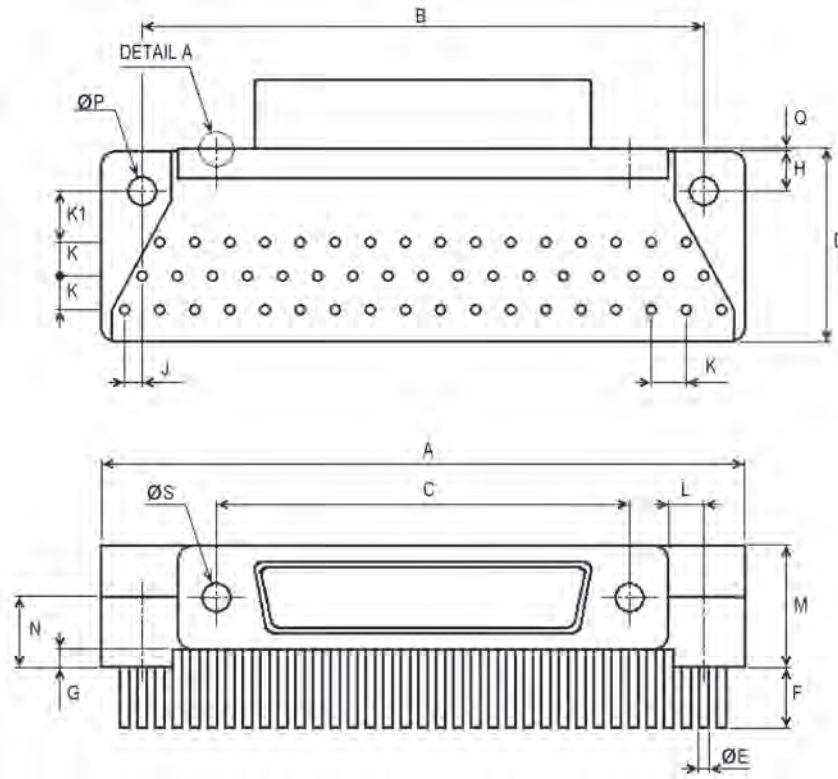

Front Shell dimensions : see page 93

Shell Size	51
A	max. 47,63 (1.875)
B	± 0,18 (.007) 40,64 (1.600)
C	± 0,13 (.005) 30,86 (1.215)
D	max. 14,35 (.565)
øE	max. 0,46 (.018)
F	± 0,35 (.014) 4,50 (.177)
G	± 0,20 (.008) 1,50 (.059)
H	± 0,38 (.015) 3,17 (.125)
J	Typ. 1,27 (.050)
K	Typ. 2,54 (.100)
K1	± 0,25 (.010) 3,81 (.150)
L	± 0,05 (.002) 2,05 (.081)
M	± 0,10 (.004) 10,25 (.404)
N	± 0,15 (.006) 5,96 (.235)
øP (*)	± 0,15 (.006) 2,45 (.096)
Q	± 0,10 (.004) 0,30 (.012)
R	min. 4,60 (.181)
øS	Typ. 2-56-UNC-2B

Note (*) : Maximum torque 0.44 Nm.

Connector Type FR136A / 90° bent PCB Terminations, Narrow Profile (Shell Size 9)

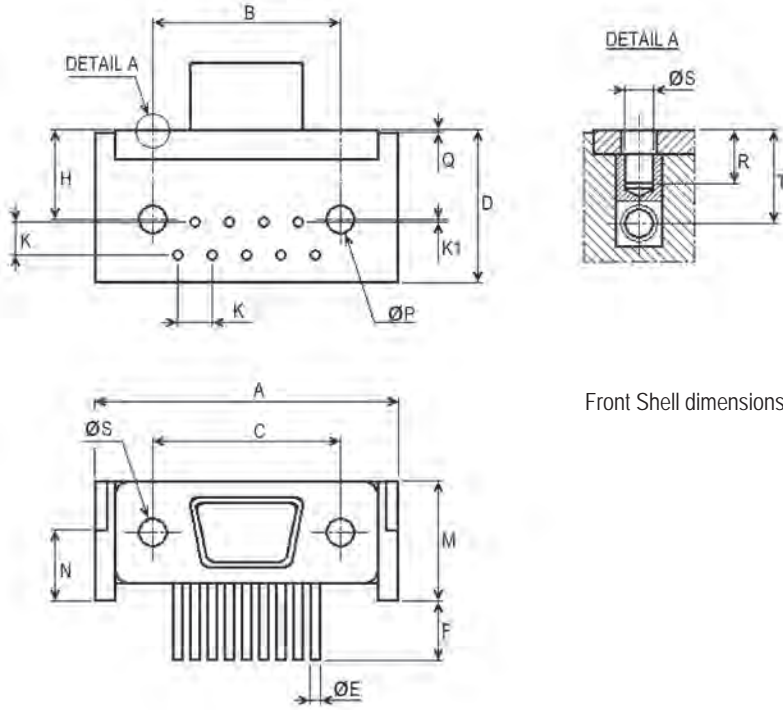

Front Shell dimensions : see page 93

Shell Size		9
A	max.	23,12 (.910)
B	± 0,13 (.005)	14,35 (.565)
C	± 0,13 (.005)	14,35 (.565)
D	max.	11,50 (.453)
øE	max.	0,46 (.018)
F	± 0,20 (.008)	3,50 (.138)
H	± 0,38 (.015)	6,86 (.270)
K	Typ.	2,54 (.100)
K1	Typ.	0,20 (.008)
M	± 0,10 (.004)	9,10 (.358)
N	± 0,15 (.006)	5,30 (.209)
øP	Typ.	M2 x 0,4
Q	± 0,10 (.004)	0,30 (.012)
R	min.	4,60 (.181)
øS	Typ.	2-56-UNC-2B
T	± 0,38 (.015)	6,86 (.270)

MDM

Connector Type FR139 / Straight PCB Terminations (Shell Sizes 9 to 37)

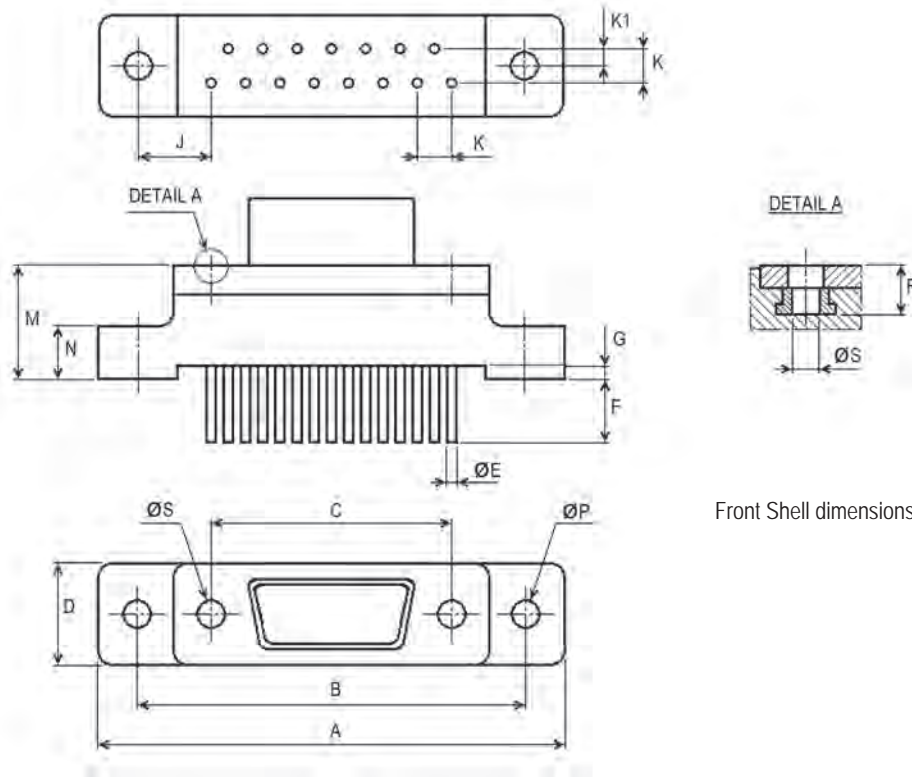

Front Shell dimensions : see page 93

Shell Size		9	15	21	25	31	37
A	max.	35,31 (1.390)	35,31 (1.390)	42,93 (1.690)	44,20 (1.740)	51,82 (2.040)	59,44 (2.340)
B	± 0,18 (.007)	29,21 (1.150)	29,21 (1.150)	36,83 (1.450)	38,10 (1.500)	45,72 (1.800)	53,34 (2.100)
C	± 0,13 (.005)	14,35 (.565)	18,16 (.715)	21,97 ^B (.865)	24,51 (.965)	28,32 (1.115)	32,13 (1.265)
D	max.	7,82 (.308)	7,82 (.308)	7,82 ^A (.308)	7,82 (.308)	7,82 (.308)	7,82 (.308)
ØE	max.	0,46 (.018)	0,46 (.018)	0,46 (.018)	0,46 (.018)	0,46 (.018)	0,46 (.018)
F	± 0,35 (.014)	4,50 (.177)	4,50 (.177)	4,50 (.177)	4,50 (.177)	4,50 (.177)	4,50 (.177)
G	± 0,10 (.004)	1,00 (.039)	1,00 (.039)	1,00 (.039)	1,00 (.039)	1,00 (.039)	1,00 (.039)
J	Typ.	9,53 (.375)	5,72 (.225)	5,72 (.225)	3,81 (.150)	3,81 (.150)	3,81 (.150)
K	Typ.	2,54 (.100)	2,54 (.100)	2,54 (.100)	2,54 (.100)	2,54 (.100)	2,54 (.100)
K1	± 0,25 (.010)	1,27 (.050)	1,27 (.050)	1,27 (.050)	1,27 (.050)	1,27 (.050)	1,27 (.050)
M	± 0,20 (.008)	8,82 (.347)	8,82 (.347)	8,82 (.347)	8,82 (.347)	8,82 (.347)	8,82 (.347)
N	± 0,10 (.004)	4,10 (.161)	4,10 (.161)	4,10 (.161)	4,10 (.161)	4,10 (.161)	4,10 (.161)
ØP (*)	± 0,15 (.006)	2,45 (.096)	2,45 (.096)	2,45 (.096)	2,45 (.096)	2,45 (.096)	2,45 (.096)
R	min.	4,60 (.181)	4,60 (.181)	4,60 (.181)	4,60 (.181)	4,60 (.181)	4,60 (.181)
ØS	Typ.	2-56-UNC-2B	2-56-UNC-2B	2-56-UNC-2B	2-56-UNC-2B	2-56-UNC-2B	2-56-UNC-2B

Note (*) : Maximum torque 0.44 Nm.

MDM

Mounting Condition

Z : 5,21 (.205) max.

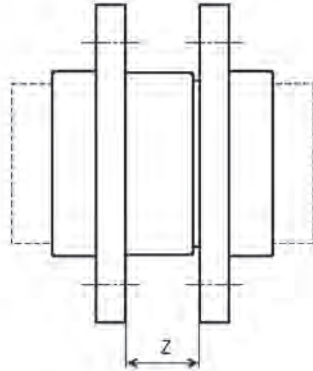

Contacts

Plug (Male Contact)

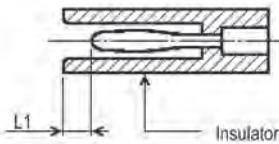

	Min.	Max.
L1	0,25 (.010)	0,91 (.036)
L2	3,30 (.130)	3,66 (.144)

Receptacle (Female Contact)

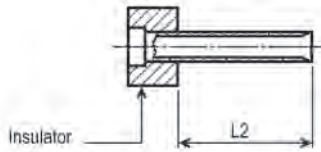

Float Mount (option F)

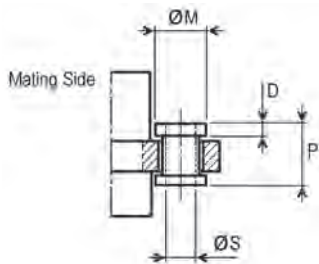

ØM	3,81 ± 0,08 (.150 ± .003)
ØS	2,29 ± 0,04 (.090 ± .002)
D	1,04 ± 0,08 (.041 ± .003)
P	4,70 max. (.185 max.)
Allowable diametral float	0,36 ± 0,10 (.014 ± .004)
Max. allowable axial float	0,51 (.020)

Captive Nut (option E)

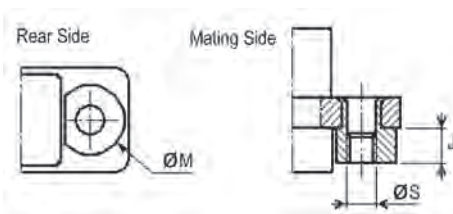

ØM	5,10 max. (.200 max.)
ØS	2-56-UNC-2B
J	2,60 max. (.102 max.)

Arrangements

Front view of Plugs (use mirror view for Receptacle)

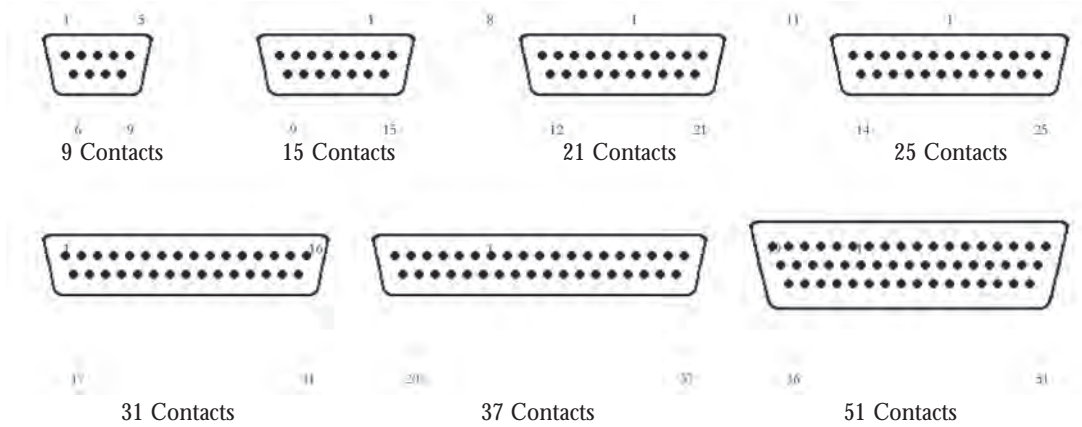

Panel Cutouts

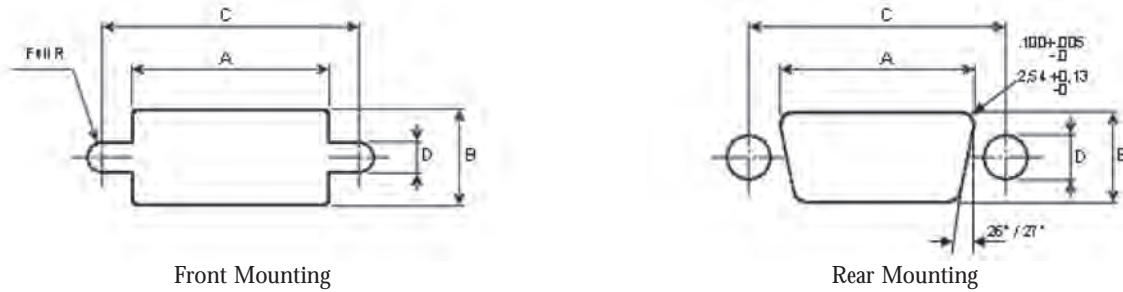

Front Mounting	Shell Size	A + 0,10 (.004) / - 0,00 (.000)	B + 0,10 (.004) / - 0,00 (.000)	C + 0,13 (.005) / - 0,00 (.000)	D + 0,13 (.005) / - 0,00 (.000)
	9	10,36 (.408)	6,88 (.271)	14,48 (.570)	2,26 (.089)
	15	14,17 (.558)	6,88 (.271)	18,29 (.720)	2,26 (.089)
	21	17,98 (.708)	6,88 (.271)	22,10 (.870)	2,26 (.089)
	25	20,52 (.808)	6,88 (.271)	24,64 (.970)	2,26 (.089)
	31	24,33 (.958)	6,88 (.271)	28,45 (1.120)	2,26 (.089)
	37	28,14 (1.108)	6,88 (.271)	32,26 (1.270)	2,26 (.089)
	51	26,87 (1.058)	8,00 (.315)	30,99 (1.220)	2,26 (.089)

Rear Mounting	Shell Size	A + 0,10 (.004) / - 0,00 (.000)	B + 0,10 (.004) / - 0,00 (.000)	C + 0,13 (.005) / - 0,00 (.000)	D + 0,02 (.001) / - 0,00 (.000)
	9	10,19 (.401)	6,40 (.252)	14,48 (.570)	3,18 (.125)
	15	14,00 (.551)	6,40 (.252)	18,29 (.720)	3,18 (.125)
	21	17,81 (.701)	6,40 (.252)	22,10 (.870)	3,18 (.125)
	25	20,34 (.801)	6,40 (.252)	24,64 (.970)	3,18 (.125)
	31	24,16 (.951)	6,40 (.252)	28,45 (1.120)	3,18 (.125)
	37	27,97 (1.101)	6,40 (.252)	32,26 (1.270)	3,18 (.125)
	51	26,70 (1.51)	7,49 (.295)	30,99 (1.220)	3,18 (.125)

Note : Front and Rear Mounting accommodate 2-56 UNC-2A screws.

MDM

PCB Layout / 90° bent PCB Terminations (Size 9 to 37)

9 Contacts

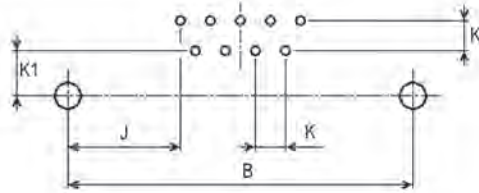

15 Contacts

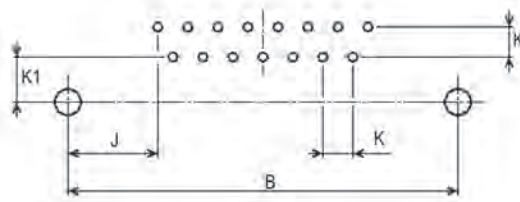

21 Contacts

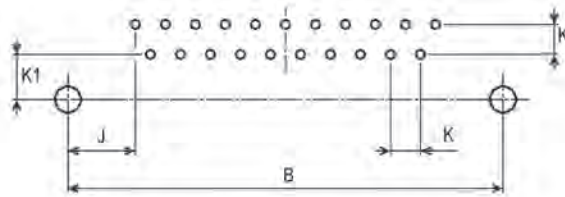

25 Contacts

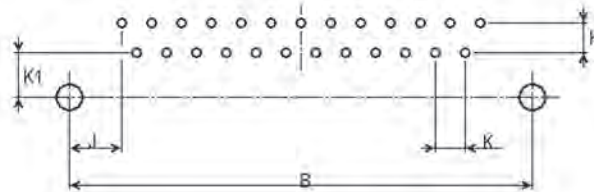

31 Contacts

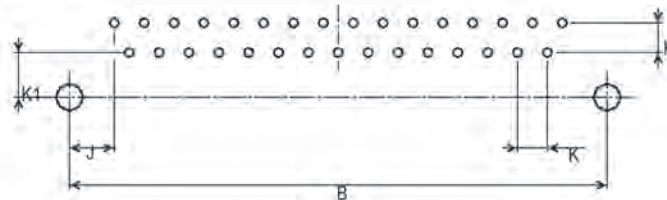

37 Contacts

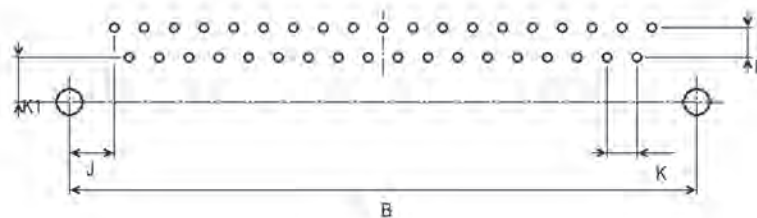

Dimensions : See page 95

MDM

PCB Layout / 90° bent PCB Terminations (Size 51)

51 Contacts

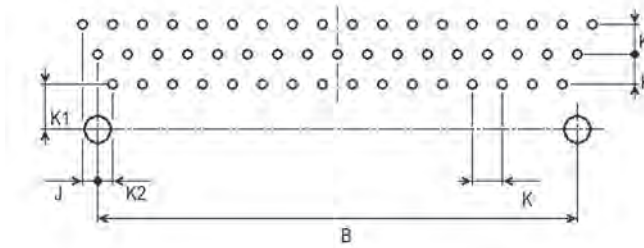

PCB Layout / 90° bent PCB Terminations, Narrow Profile (Size 9)

9 Contacts / Narrow

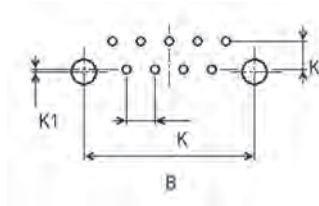

Dimensions Layout / 90° bent PCB

Shell Size	9	15	21	25	31	37	51	9 Narrow
B	29,21 (1.150)	33,02 (1.300)	36,83 (1.450)	39,37 (1.550)	45,72 (1.800)	53,34 (2.100)	40,64 (1.600)	14,35 (.565)
J	9,53 (.375)	7,62 (.300)	5,72 (.225)	4,45 (.175)	3,81 (.150)	3,81 (.150)	1,27 (.050)	N.A.
K	2,54 (.100)	2,54 (.100)	2,54 (.100)	2,54 (.100)	2,54 (.100)	2,54 (.100)	2,54 (.100)	2,54 (.100)
K1	3,81 (.150)	3,81 (.150)	3,81 (.150)	3,81 (.150)	3,81 (.150)	3,81 (.150)	3,81 (.150)	0,20 (.008)
K2	N.A.	N.A.	N.A.	N.A.	N.A.	K	N.A.	1,27 (.050)

Dimensions Layout / Straight PCB

Shell Size	9	15	21	25	31	37
B	29,21 (1.150)	29,21 (1.150)	36,83 (1.450)	38,10 (1.500)	45,72 (1.800)	53,34 (2.100)
J	9,53 (.375)	5,72 (.225)	5,72 (.225)	3,81 (.150)	3,81 (.150)	3,81 (.150)
K	2,54 (.100)	2,54 (.100)	2,54 (.100)	2,54 (.100)	2,54 (.100)	2,54 (.100)
K1	1,27 (.050)	1,27 (.050)	1,27 (.050)	1,27 (.050)	1,27 (.050)	1,27 (.050)

MDM

PCB Layout / Straight PCB Terminations (Size 9 to 37)

9 Contacts

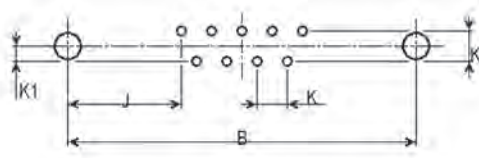

15 Contacts

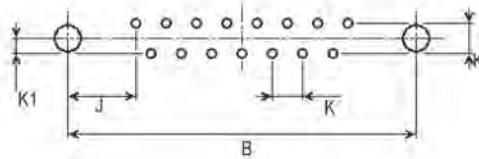

21 Contacts

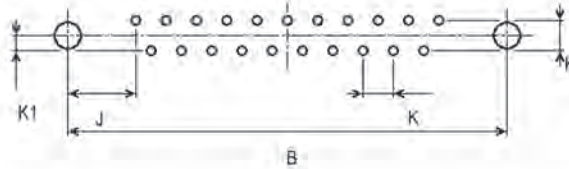

25 Contacts

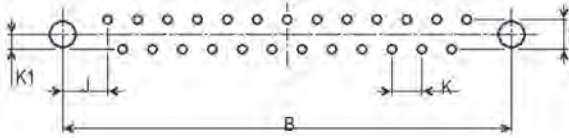

31 Contacts

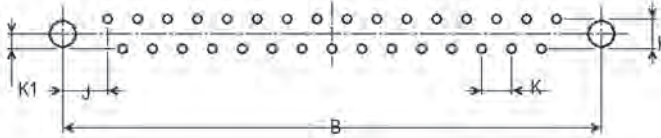

37 Contacts

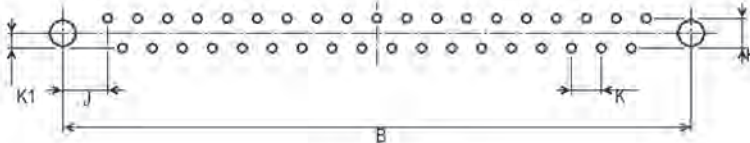

Dimensions : See page 95

PCB Layout for termination FR116 / L2 identically with insulator layout

2 adjacent contacts: 1,27 mm (.050)

2 contact rows: 1,09 (.043)

MDM

How to order – ESA quality level

Description (example) : 340102901B 25PFR112 F

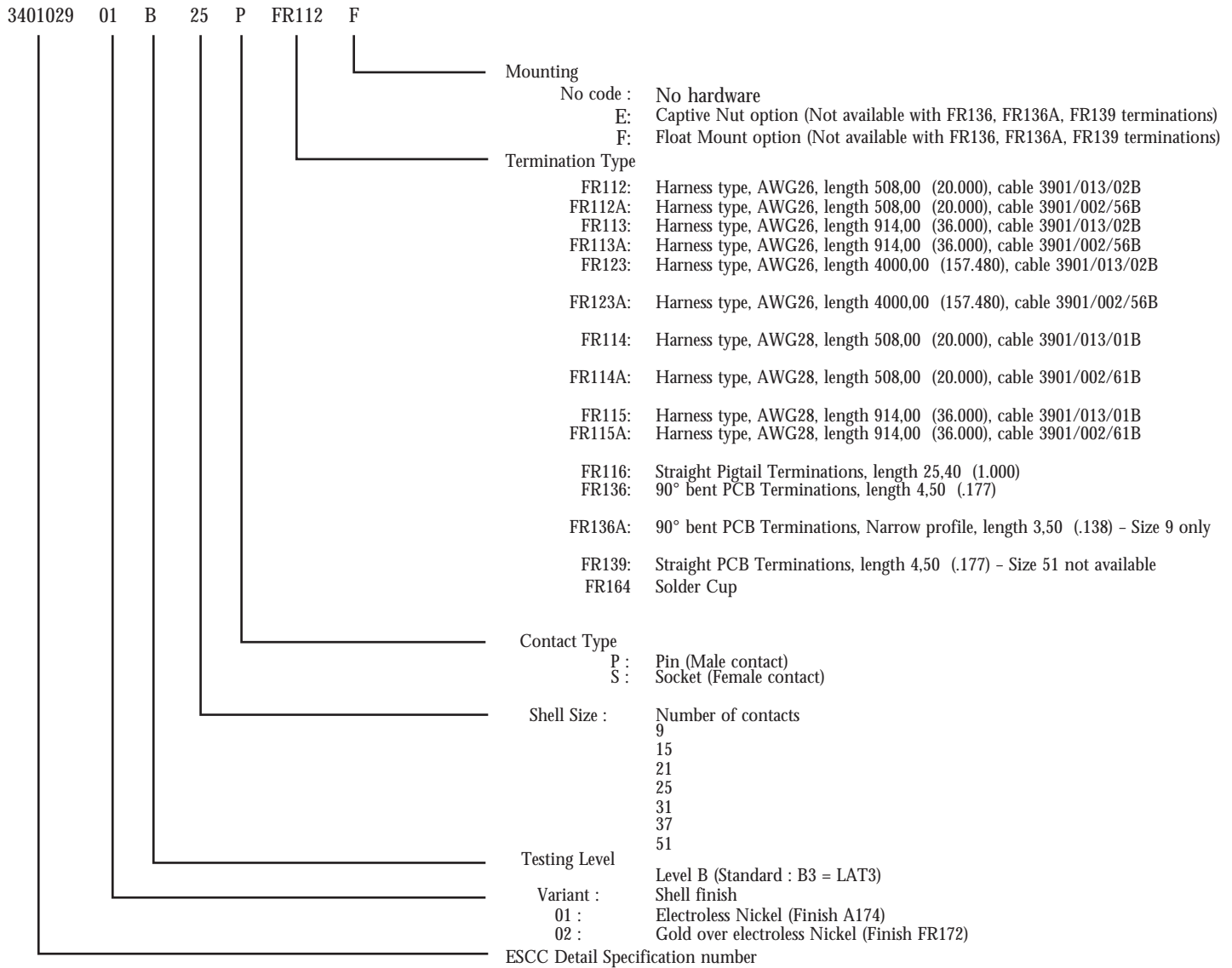

MDM

FR164 : SOLDER CUP TYPE CONTACT – QUALITY LEVEL : ACCORDING TO ESA.

Connectors supplied with dust caps (not available separately)
 Other configurations available on request, consult factory.
 CDRI with description MDM-115366-xxxx

How to order - FR022 quality level

Description (example) : MDM-25PH038F-A174-FR022

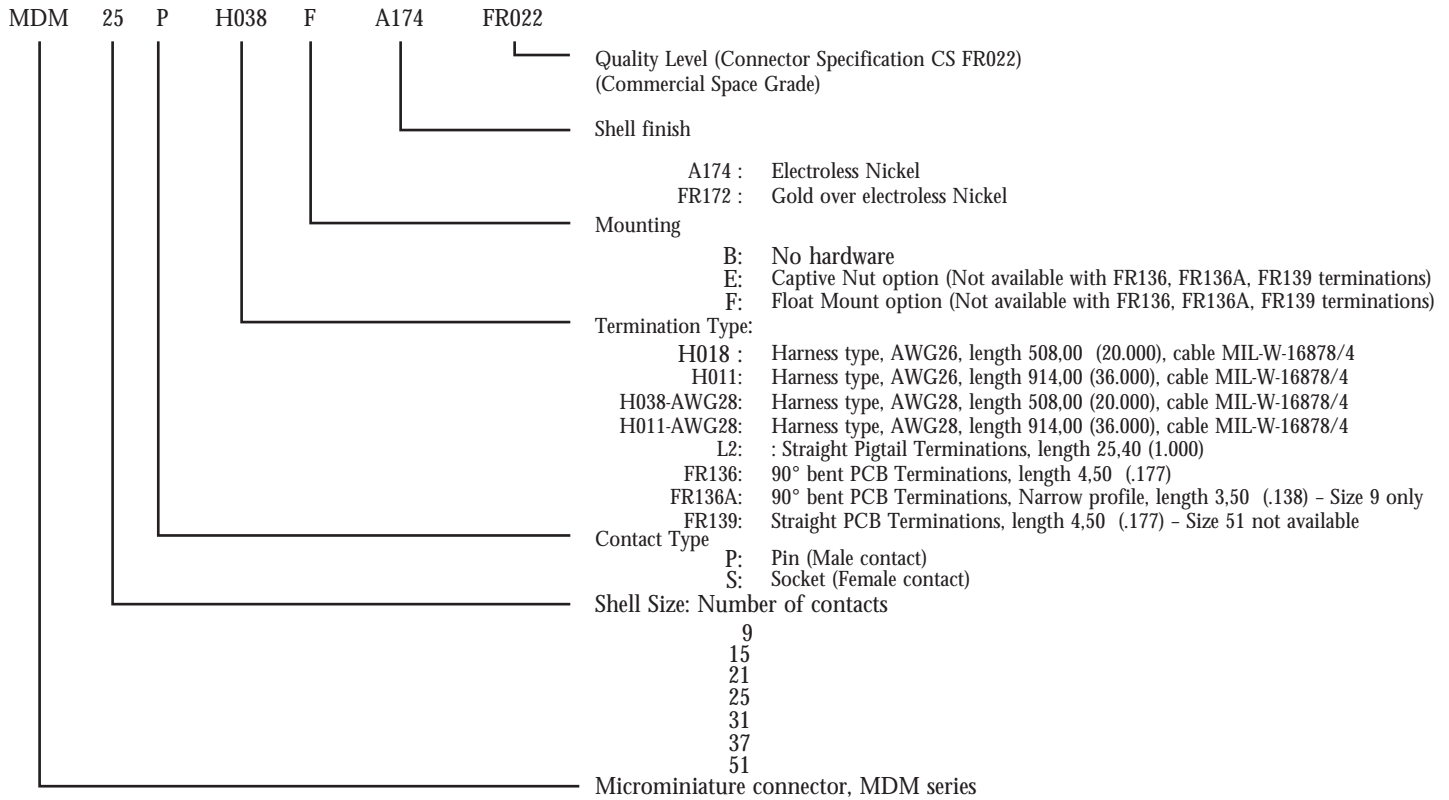

Note:
 Connectors supplied with dust caps (not available separately)
 Other configurations available on request, consult factory.
 CDRI with description MDM-115288-xxxx



High Reliability Connectors MDM Solder Bucket Contacts per FR164 C&K Specification

(Process and controls according to ESA/ESCC 3401-029)

Features/Benefits

- Compliant with ESA/ESCC specifications
- Solderable contacts
- Harnesses length flexibility

Typical Applications

- Space equipments
- Avionics / Military
- Industrials applications

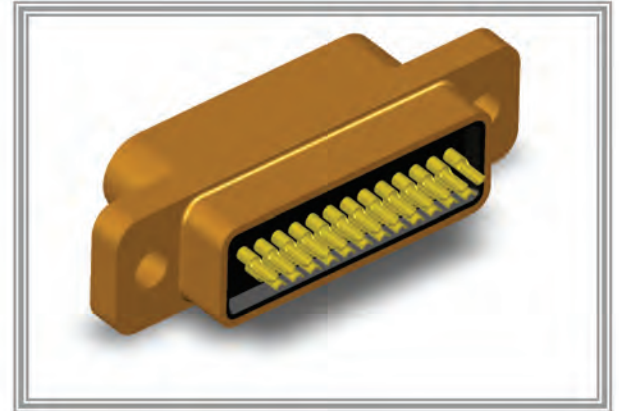

Specification

Compliant to ESA/ESCC specifications 3401/029, MIL-DTL-83513/1, MIL-DTL-83513/2 and C&K FR164 specification.
Solder bucket contacts terminations.
Compatible with MDM ESCC 3401/029, MDMA ESCC 3401/077, Savers 3401/041 and Accessories 3401/032.
PIN and SOCKETS arrangements available.
SIZE AVAILABLE : 9, 15, 21, 25, 31, 37 and 51 ways (100 ways under request)
ACCEPTED WIRES SIZE : insulated AWG 26, AWG 28 and AWG 30.
TWIST PIN CONTACTS TECHNOLOGY.
Distance between 2 adjacent contacts : 1.27mm (.050 inch)
Distance between 2 contacts rows : 1.09mm (.043 inch)

Quality Level

ESA / ESCC : code FR164 (Flying model)
Standard space : code FR022 (Engineering Model)

Process to use it

Wires stripping
Cables soldering onto contacts

Options

Optional captive nuts or float mounting (consult factory)

Packaging

Individual packaging and traceability associated as per ESA/ESCC specifications
Each MDM connector is sold with a dust cap in individual plastic bag



Mechanical

Type	Mating force (N.max)	Contact retention force (N.max)	Max Weight (g)*
Size 9	20	22.25	2.2
Size 15	33	22.25	3
Size 21	47	22.25	3.8
Size 25	55	22.25	4.3
Size 31	69	22.25	5.1
Size 37	82	22.25	5.9
Size 51	113	22.25	7.2

* Weights without cables, floating eyelets captive nuts and contacts

Electrical

Working Voltage (Sea level) :	150 Vrms
Rated Current AWG 26	2.5 A
Rated Current AWG 28	1.5A

Temperature Range

Operating Temperature range	-55 to +125 °C
Storage Temperature Range	-65 to +125 °C

High Reliability Connectors MDM Solder Bucket Contacts per FR164 C&K Specification

(Process and controls according to ESA/ESCC 3401-029)

How to Order :

CONNECTORS :

Our easy build-a-connector concept allows you to mix and match options to create the MDM you need. To order, select desired option from each category and place it in the appropriate box.

For any part number different from those listed above, please consult your local C&K components representative.

- Connectors MDM According to ESA/ESCC 3401-029 Specification (Flying Models) :

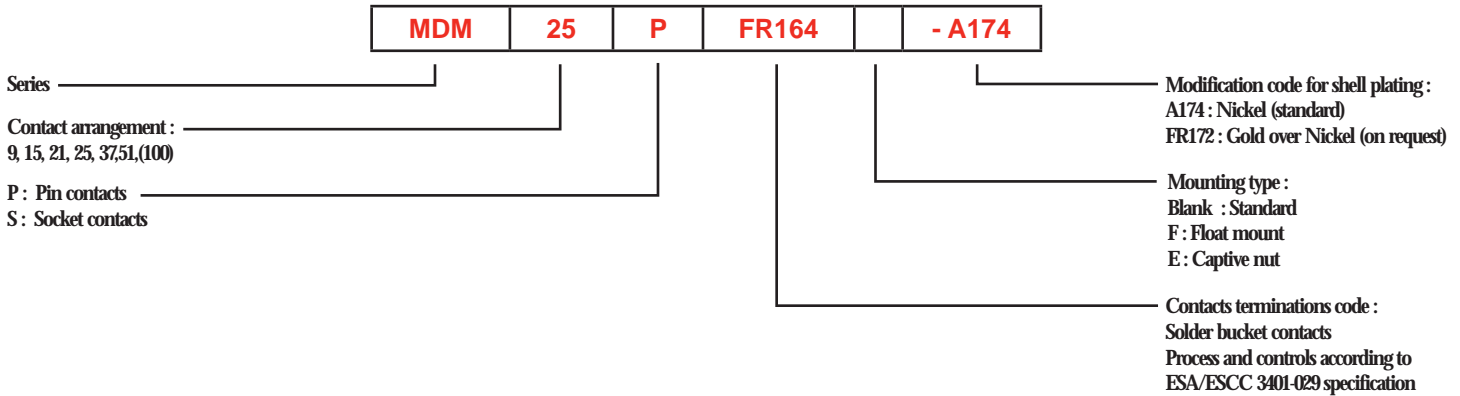

- Connectors MDM According to C&K FR022 Specification (Engineering Models) :

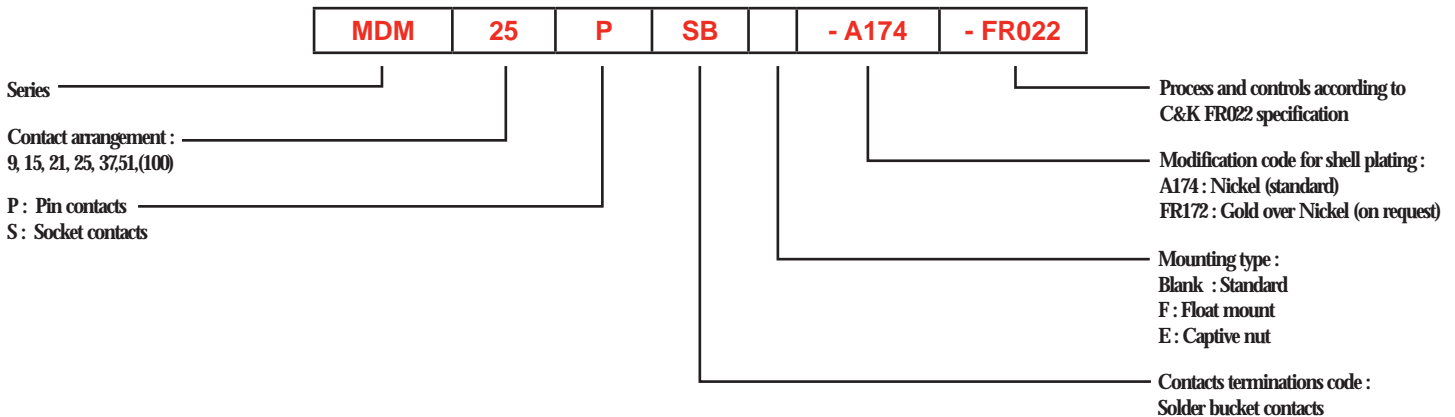

Materials and finishes :

Shells	Aluminium alloy Finish A174 : 25,4 µm min. (1000 µin min.) electroless Nickel over Copper underlay Finish FR172 : 2,54 µm min. (100 µin min.) Gold over 25,4 µm min. (1000 µin min.) electroless Nickel
Insulators	LCP (Liquid Crystal Polymer) thermoplastic material, UL 94-V0, glass-filled, black color
Female contacts	Copper alloy / Finish : 1,27 µm (50 µin) min. Gold over Copper underlay
Male contacts	Copper alloy / Finish : 1,27 µm (50 µin) min. Gold over Copper underlay
Interfacial Seals	Fluorosilicone elastomere, pink color
Accessories (F or E)	Stainless Steel type 303 or 316, passivated
Dust Caps	Polyethylene thermoplastic material, transparent pink color

(Process and controls according to ESA/ESCC 3401-029)

Physical Dimensions :

Connectors MDM Plug (Male contacts)

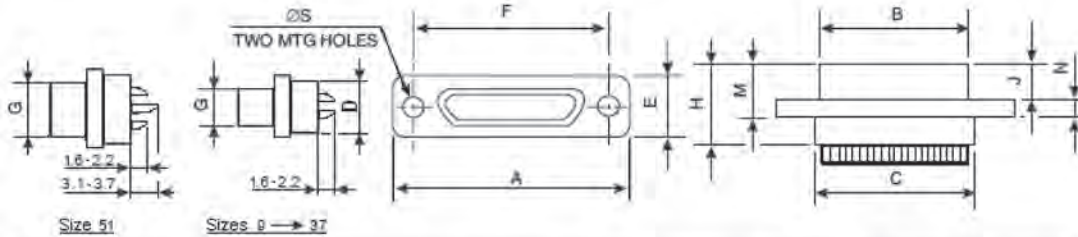

SHELL SIZE		A	B	C	D	E	F	G	H	J	M	N	Ø S
9	Max.	19,94	8,46	10,16	6,86	7,82	14,48	4,69	10,57	4,72	7,26	2,49	2,39
	min.	-	-	-	-	-	14,22	-	-	-	-	2,23	2,23
15	Max.	23,75	12,27	13,97	6,86	7,82	18,29	4,69	10,57	4,72	7,26	2,49	2,39
	min.	-	-	-	-	-	18,03	-	-	-	-	2,23	2,23
21	Max.	27,56	16,08	17,78	6,86	7,82	22,10	4,69	10,57	4,72	7,26	2,49	2,39
	min.	-	-	-	-	-	21,84	-	-	-	-	2,23	2,23
25	Max.	30,10	18,62	20,32	6,86	7,82	24,64	4,69	10,57	4,72	7,26	2,49	2,39
	min.	-	-	-	-	-	24,38	-	-	-	-	2,23	2,23
31	Max.	33,91	22,43	24,13	6,86	7,82	28,45	4,69	10,57	4,72	7,26	2,49	2,39
	min.	-	-	-	-	-	28,19	-	-	-	-	2,23	2,23
37	Max.	37,72	26,24	27,94	6,86	7,82	32,26	4,69	10,57	4,72	7,26	2,49	2,39
	min.	-	-	-	-	-	32,00	-	-	-	-	2,23	2,23
51	Max.	36,45	24,97	26,67	7,87	8,92	30,99	5,76	10,57	4,72	7,26	2,49	2,39
	min.	-	-	-	-	-	30,73	-	-	-	-	2,23	2,23

Connectors MDM Receptacle (Female contacts)

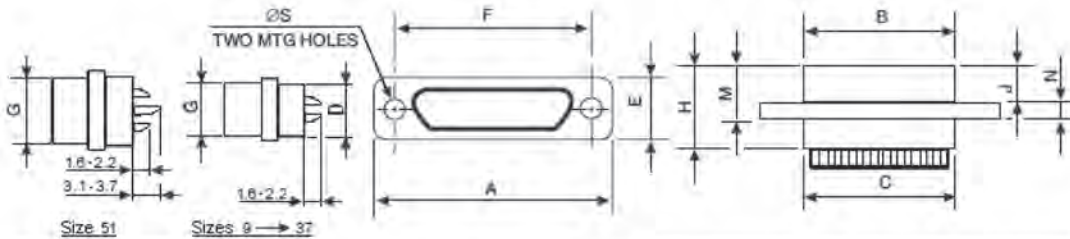

SHELL SIZE		A	B	C	D	E	F	G	H	J	M	N	Ø S
9	Max.	19,94	10,16	10,16	6,86	7,82	14,48	6,38	10,90	5,05	7,59	2,49	2,39
	min.	-	-	-	-	-	14,22	-	-	-	-	2,23	2,23
15	Max.	23,75	13,97	13,97	6,86	7,82	18,29	6,38	10,90	5,05	7,59	2,49	2,39
	min.	-	-	-	-	-	18,03	-	-	-	-	2,23	2,23
21	Max.	27,56	17,78	17,78	6,86	7,82	22,10	6,38	10,90	5,05	7,59	2,49	2,39
	min.	-	-	-	-	-	21,84	-	-	-	-	2,23	2,23
25	Max.	30,10	20,32	20,32	6,86	7,82	24,64	6,38	10,90	5,05	7,59	2,49	2,39
	min.	-	-	-	-	-	24,38	-	-	-	-	2,23	2,23
31	Max.	33,91	24,13	24,13	6,86	7,82	28,45	6,38	10,90	5,05	7,59	2,49	2,39
	min.	-	-	-	-	-	28,19	-	-	-	-	2,23	2,23
37	Max.	37,72	27,94	27,94	6,86	7,82	32,26	6,38	10,90	5,05	7,59	2,49	2,39
	min.	-	-	-	-	-	32,00	-	-	-	-	2,23	2,23
51	Max.	36,45	26,67	26,67	7,87	8,92	30,99	7,47	10,90	5,05	7,59	2,49	2,39
	min.	-	-	-	-	-	30,73	-	-	-	-	2,23	2,23

Recommended instruction :

Wire stripping :

Cut wires to length and strip insulation per above illustration. Check for broken or frayed wires.

Recommended wire trim length



Recommended wire

- 3901 013 01 B : PTFE INSULATED WIRE AWG 28
- 3901 013 02 B : PTFE INSULATED WIRE AWG 26
- 3901 002 61 B : POLYIMIDE INSULATED WIRE AWG 28
- 3901 002 56 B : POLYIMIDE INSULATED WIRE AWG 26

Connector Savers

Description

Composed of 1 Plug and 1 Receptacle, wired pin to pin and fixed together by epoxy at their rear ends.

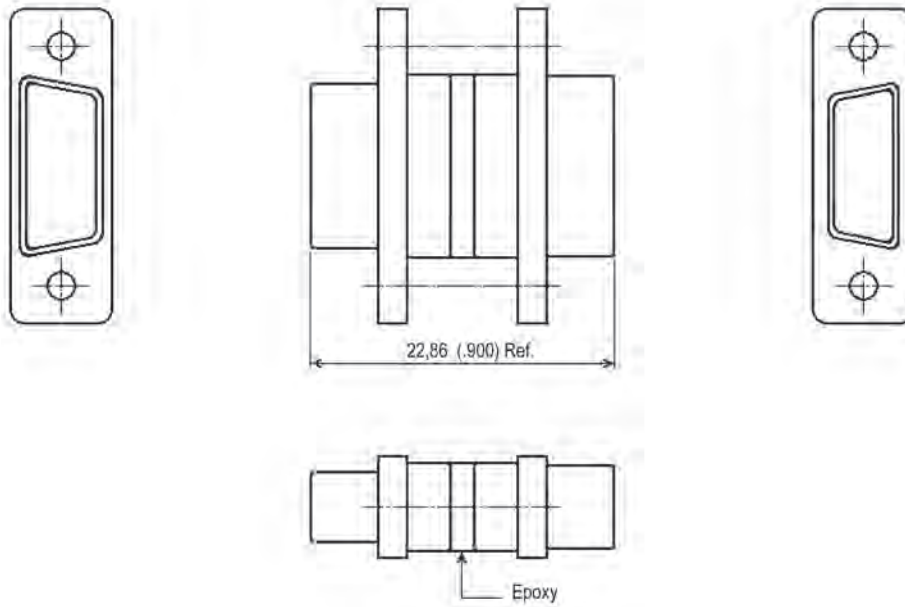

Front Shell Dimensions : see page 7

Installation

Mounting Condition : Same as for the Connectors, at each end.

Fixing by using the relevant Hardware : Screwlock assembly for connector savers (supplied separately).

Cross References

<u>Shell Size</u>	<u>Description ESCC</u>	<u>Description FR022</u>
9	340104101B 9PS	MDM-115288-372-A174-FR022
15	340104102B 15PS	MDM-115288-373-A174-FR022
21	340104103B 21PS	MDM-115288-374-A174-FR022
25	340104104B 25PS	MDM-115288-375-A174-FR022
31	340104105B 31PS	MDM-115288-376-A174-FR022
37	340104106B 37PS	MDM-115288-377-A174-FR022
51	340104107B 51PS	MDM-115288-378-A174-FR022

Note : Supplied only with shell finish A174 (Electroless Nickel)

SAVERS

Hardware

General

Hardwares are the screwlock assemblies or the brackets used for the mounting of connectors on panels or PCB, or for the fixing of plugs and receptacles.

They are not fixed on the connectors and are supplied separately.

Hardwares are supplied by pairs : A reference, identified by the Description or **by the Part Number, is for a pair of hardwares**, what is necessary for the mounting or the fixing of a connector.

ESCC 3401/032 Variants

<u>Variant</u>	<u>Application</u>	<u>Note</u>
01	Assy / Front panel mounting	Obsolete / Replaced by variants 07 + 08
02	Assy / Rear panel mounting	Obsolete / Replaced by variants 07 + 09
03	Brackets / Size 9 to 37	
04	Brackets / Size 51	
05	Assy / Connector savers	Obsolete / Replaced by variant 10
06	Screwlock / Connector FR136/FR139	Obsolete / Replaced by variant 11
07	Sub-assy harness side	New
08	Sub-assy panel side / Front panel mounting	New
09	Sub-assy panel side / Rear panel mounting	New
10	Assy / Connector savers	New
11	Screwlock / Connector FR136/FR139	New

Additional variants are supplied in accordance with the requirements of the ESCC Generic Specification n° 3401 for mounting options not covered by the ESCC qualified variants (sub-assemblies or rear panel mounting with different panel thicknesses).

All these variants are available with the Quality Level FR022.

Obsolete and New References

A redesign of the whole range of Hardwares was recently performed in order to increase their robustness and to optimize their homogeneity :

- Screwlocks with a cylindrical base, for a better tightening against the shell or the panel (instead of the previous hexagonal base).
- Screwlocks with optimized threaded hole depth, for increasing the torque security and the introduction of :
 - a minimum torque value (guarantee of the correct fixing of the connector)
 - a maximum torque value (prevention of the screwlocks from damage during the fixing operation)
- Same screw used for all the mounting configurations.

The references identified as "Obsolete (1)" in the Cross References table will be no more supplied and will be progressively replaced in the new designs by the equivalent references identified as "New". For the availability of the obsolete references for the existing applications, consult factory.

The references identified as "Obsolete (2)" in the Cross References table, concerning the mounting on panels 2,40 (.093) thick, are no more available.

The obsolete references are shown for historical reasons and for a clear identification of the alternative new references.

The mixing of the obsolete references with the new references is not authorized.

To avoid any confusions, the new references are clearly identifiable by :

- A groove on the cylindrical area localized between the head and the threaded end of the screw.
- The cylindrical base of the hexagonal area of the screwlocks.

The Reference descriptions are distributed in 3 categories :

- ESCC : Qualified variants per the ESCC Detail Specification n° 3401/032.
- According to ESCC : Not qualified variants, supplied in accordance with the requirements of the ESCC Generic Specification n° 3401.
- FR022 : Variants supplied per the C&K Connector Specification CS FR022.

Application	Details	Item No *	ESCC	According to ESCC	FR022	Note
Front panel mounting	Assembly	1	340103201B replaced by 340103207B + 340103208B		MDM-322-9500-000-FR022 replaced by MDM-115288-6916-FR022 + MDM-115288-6917-FR022	Obsolete (1)
	Sub-assembly/harness side	2		MDM-322-9501-000C replaced by 340103207B	MDM-322-9501-000-FR022 replaced by MDM-115288-6916-FR022	Obsolete (1)
	Sub-assembly/panel side	3		MDM-322-9502-000C replaced by 340103208B	MDM-322-9502-000-FR022 replaced by MDM-115288-6917-FR022	Obsolete (1)
	Sub-assembly/harness side	4	340103207B		MDM-115288-6916-FR022	New
	Sub-assembly / panel side	5	340103208B		MDM-115288-6917-FR022	New
Rear panel mounting	Assembly/Panel 1,60 (.063)	6	340103202B replaced by 340103207B + 340103209B		MDM-115288-607-FR022 replaced by MDM-115288-6916-FR022 + MDM-115288-6920-FR022	Obsolete (1)
	Sub-assembly / harness side	7		MDM-322-8751-000C replaced by 340103207B	MDM-322-8751-000-FR022 replaced by MDM-115288-6916-FR022	Obsolete (1)
	Sub-assembly/panel side 0,80 (.031)	8		MDM-320-9505-004C replaced by MDM-115366-9223C	MDM-320-9505-004-FR022 replaced by MDM-115288-6918-FR022	Obsolete (1)
	Sub-assembly/panel side 1,20 (.047)	9		MDM-320-9505-005C replaced by MDM-115366-9224C	MDM-320-9505-005-FR022 replaced by MDM-115288-6919-FR022	Obsolete (1)
	Sub-assembly / panel side 1,60 (.063)	10		MDM-320-9505-006C replaced by 340103209B	MDM-320-9505-006-FR022 replaced by MDM-115288-6920-FR022	Obsolete (1)
	Sub-assembly / panel side 2,40 (.094)	11		MDM-320-9505-007C No replacement.	MDM-320-9505-007-FR022 No replacement	Obsolete (2)
	Sub-assembly / harness side	12	340103207B		MDM-115288-6916-FR022	New
	Sub-assembly / panel side 0,80 (.031)	13		MDM-115366-9223C	MDM-115288-6918-FR022	New
	Sub-assembly / panel side 1,20 (.047)	14		MDM-115366-9224C	MDM-115288-6919-FR022	New
	Sub-assembly / panel side 1,60 (.063)	15	340103209B		MDM-115288-6920-FR022	New

ACCESSORIES

Brackets	Shell size 9 to 37	16	340103203B		MDM-015-9516-002-FR022	Unchanged
	Shell size 51	17	340103204B		MDM-015-9516-003-FR022	Unchanged
Connector Savers	Assembly	18	340103205B Replaced by 340103210B		MDM-115288-380-FR022 Replaced by MDM-115288-6921-FR022	Obsolete (1)
	Assembly	19	340103210B		MDM-115288-6921-FR022	New
Connector FR136/139	Front panel mounting	20	340103206B Replaced by 340103211B		MDM-115288-405-FR022 Replaced by MDM-115288-6922-FR022	Obsolete (1)
	Rear panel mounting 0,80(.031)	21		MDM-115366-9203C, replaced by MDM-115366-9225C	MDM-115288-602-FR022 Replaced by MDM-115288-6923-FR022	Obsolete (1)
	Rear panel mounting 1,20(.047)	22		MDM-115366-9204C, replaced by MDM-115366-9226C	MDM-115288-603-FR022 Replaced by MDM-115288-6924-FR022	Obsolete (1)
	Rear panel mounting 1,60(.063)	23		MDM-115366-9205C, replaced by MDM-115366-9227C	MDM-115288-604-FR022 Replaced by MDM-115288-6925-FR022	Obsolete (1)
	Rear panel mounting 2,40(.094)	24		MDM-115366-9206C No replacement	MDM-115288-605-FR022 No replacement	Obsolete (2)
	Front panel mounting	25	340103211B		MDM-115288-6922-FR022	New
	Rear panel mounting 0,80(.031)	26		MDM-115366-9225C	MDM-115288-6923-FR022	New
	Rear panel mounting 1,20(.047)	27		MDM-115366-9226C	MDM-115288-6924-FR022	New
	Rear panel mounting 1,60(.063)	28		MDM-115366-9227C	MDM-115288-6925-FR022	New

The Reference descriptions are distributed in 3 categories :

- Obsolete (1) : No more supplied, replaced by the equivalent "New" references.
Per ESA is specified to use the **NEW** items as a replacement for the **OBSOLETE** items.
- Obsolete (2) : No more available.

Item No * : Used for the compatibility table page 121.
The compatibility is based on the dimensions of the parts.
Compatibility of 2 items available within 2 different categories (example between ESCC and FR022 variants).

Screwlock assembly, front panel mounting – Old version

Description ESCC : 340103201B
 Description FR022 : MDM-322-9500-000-FR022
 Total weight for a pair : 1.80 g max.
 Composed of 2 sub-assemblies :

1 - Screwlock sub-assembly, harness side, front panel mounting –old version

Description according to ESCC : MDM-322-9501-000C
 Description FR022 : MDM-322-9501-000-FR022
 Composed of : 2 Screws + 2 Clips
 Torque value for screw : 0.28 Nm max.

A	4,83 ± 0,25 (.190 ± .010)
B	4,45 max. (.175 max.)
C	1,97 ± 0,19 (.078 ± .007)
D1	2-56 UNC-2A
ØJ	3,68 max. (.145 max.)
K	7,42 max. (.292 max.)
L1	2,10 ± 0,19 / - 0,10 (.083 ± .007 / - .004)
ØM	2,35 ± 0,06 (.093 ± .002)
S	0,68 ± 0,10 (.027 ± .004)
V	0,38 ± 0,03 (.015 ± .001)

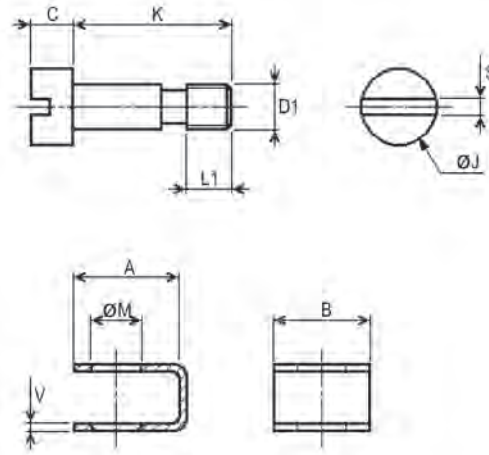

2 - Screwlock sub-assembly, panel side, front panel mounting –old version

Description according to ESCC : MDM-322-9502-000C
 Description FR022 : MDM-322-9502-000-FR022
 Composed of : 2 Screwlocks + 2 Washers + 2 Nuts
 Torque value for screwlock, male side : 0.44 Nm max.
 Torque value for screwlock, female side : 0.28 Nm max.

D1	2-56 UNC-2A
D2	2-56 UNC-2B
F1	3,17 Typ (.125 Typ)
F2	3,90 Typ (.154 Typ)
H	4,62 max. (.182 max.)
L	11,56 ± 0,25 (.455 ± .010)
L2	5,20 min. (.205 min.)
L3	3,50 min. (.138 min.)
N	1,60 ± 0,15 (.063 ± .006)
W	0,30 ± 0,03 (.012 ± .001)
W1	0,50 Typ overall (.020 Typ overall)
ØZ	4,55 ± 0,03 (.179 ± .001)

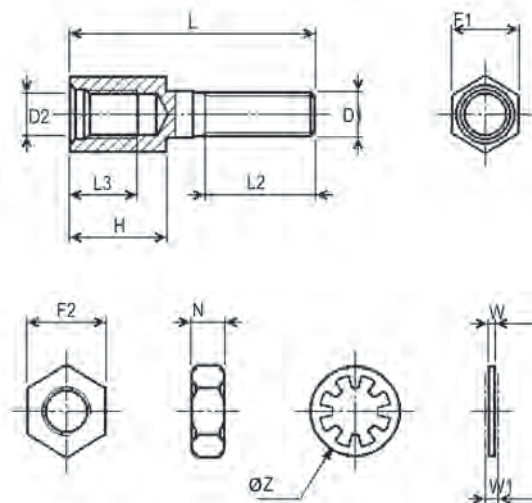

ACCESSORIES

Screwlock assembly, front panel mounting - New version

Composed of 2 sub-assemblies :

1 - Screw sub-assembly, harness side

Description ESCC : 340103207B

Description FR022 : MDM-115288-6916-FR022

Composed of : 2 Screws + 2 Clips

Total weight for a pair : 0.88 g max.

Torque value for screw : 0.28 Nm min. / 0.32 Nm max.

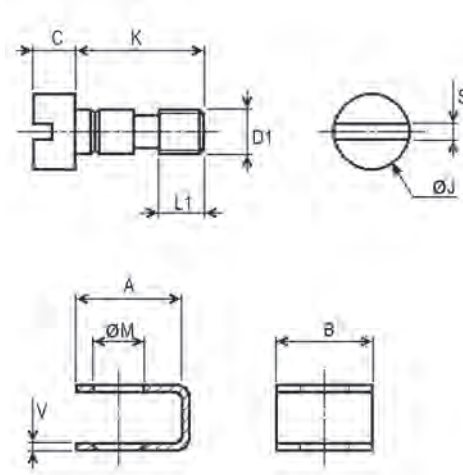

A	4,83 ± 0,25 (.190 ± .010)
B	4,45 max. (.175 max.)
C	2,00 ± 0,15 (.079 ± .006)
D1	2-56 UNC-2A
ØJ	3,68 max. (.145 max.)
K	6,00 ± 0,15 (.236 ± .006)
L1	2,10 + 0,19 / - 0,10 (.083 + .007 / - .004)
ØM	2,35 ± 0,06 (.093 ± .002)
S	0,68 ± 0,10 (.027 ± .004)
V	0,38 ± 0,03 (.015 ± .001)

2 - Screwlock sub-assembly, panel side, front panel mounting - New version

Description ESCC : 340103208B

Description FR022 : MDM-115288-6917-FR022

Composed of : 2 Screwlocks + 2 Washers + 2 Nuts

Total weight for a pair : 1.32 g max.

Torque value for screwlock, male side : 0.44 Nm min. / 0.48 Nm max.

Torque value for screwlock, female side : 0.28 Nm min. / 0.32 Nm max.

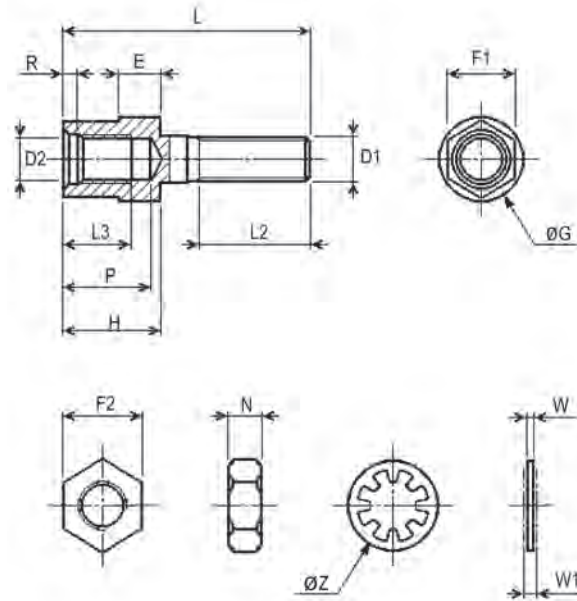

D1	2-56 UNC-2A
D2	2-56 UNC-2B
E	2,00 Typ (.079 Typ)
F1	3,17 Typ (.125 Typ)
F2	3,80 ± 0,15 (.150 ± .006)
ØG	4,00 ± 0,05 (.157 ± .002)
H	4,58 + 0,04 / - 0,03 (.180 + .002 / - .001)
L	11,60 + 0,20 / - 0,30 (.457 + .008 / - .012)
L2	5,20 min. (.205 min.)
L3	3,20 min. (.126 min.)
N	1,60 ± 0,15 (.063 ± .006)
P	4,20 max. (.165 max.)
R	0,70 Typ (.028 Typ)
W	0,30 ± 0,03 (.012 ± .001)
W1	0,50 Typ overall (.020 Typ overall)
ØZ	4,55 ± 0,03 (.179 ± .001)

ACCESSORIES

Screwlock assembly, rear panel mounting – Old version

Description ESCC, for panel thickness 1,60 (.063) : 340103202B
 Description FR022, for panel thickness 1,60 (.063) : MDM-115288-607-FR022
 Total weight for a pair : 1.80 g
 Composed of 2 sub-assemblies :

1 - Screwlock sub-assembly, harness side, rear panel mounting

Description according to ESCC : MDM-322-8751-000C
 Description FR022 : MDM-322-8751-000-FR022
 Composed of : 2 Screws + 2 Clips
 Torque value for screw : 0.28 Nm max.

A	4,83 ± 0,25 (.190 ± .010)
B	4,45 max. (.175 max.)
C	1,97 ± 0,19 (.078 ± .007)
D1	2-56 UNC-2A
øJ	3,68 max. (.145 max.)
K	6,37 max. (.251 max.)
L1	2,10 ± 0,19 / - 0,10 (.083 + .007 / - .004)
øM	2,35 ± 0,06 (.093 ± .002)
S	0,68 ± 0,10 (.027 ± .004)
V	0,38 ± 0,03 (.015 ± .001)

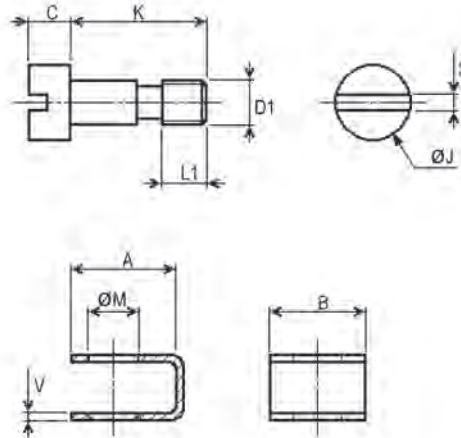

2 - Screwlock sub-assembly, panel side, rear panel mounting –old version

Panel thickness :	0,80 (.031)	1,20 (.047)	1,60 (.063)	2,40 (.094)
Description according to ESCC :	MDM-320-9505-004C	MDM-320-9505-005C	MDM-320-9505-006C	MDM-320-9505-007C
Description FR022 :	MDM-322-9505-004-FR022	MDM-322-9505-005-FR022	MDM-322-9505-006-FR022	MDM-322-9505-007-FR022
Dimension T :	0,67 ± 0,05 (.026 ± .002)	1,07 ± 0,05 (.042 ± .002)	1,47 ± 0,05 (.058 ± .002)	2,27 ± 0,05 (.089 ± .002)

Composed of : 2 Screwlocks + 2 Washers + 2 Nuts
 Torque value for screwlock, male side : 0.44 Nm max.
 Torque value for screwlock, female side : 0.28 Nm max.

D1	2-56 UNC-2A
D2	2-56 UNC-2B
F1	3,17 Typ (.125 Typ)
F2	3,90 Typ (.154 Typ)
H	4,53 ± 0,13 (.178 ± .005)
L	12,42 ± 0,25 (.489 ± .010)
L2	6,00 min. (.236 min.)
L3	3,50 min. (.138 min.)
N	1,60 ± 0,15 (.063 ± .006)
øQ	3,10 ± 0,03 (.122 ± .001)
W	0,30 ± 0,03 (.012 ± .001)
W1	0,50 Typ overall (.020 Typ overall)
øZ	4,55 ± 0,03 (.179 ± .001)

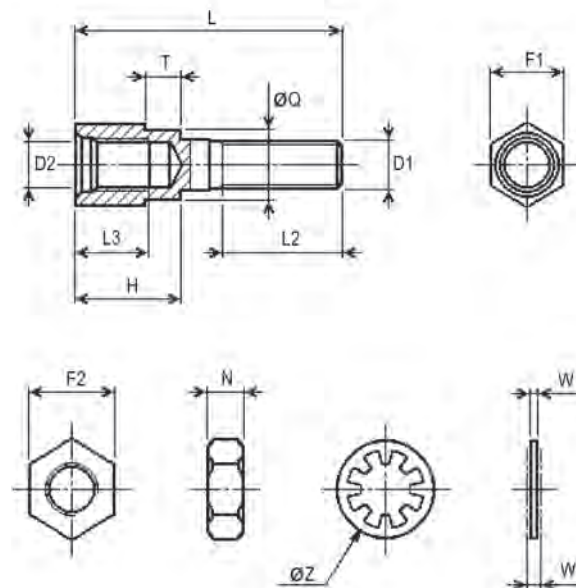

ACCESSORIES

Screwlock assembly, rear panel mounting - New version

Composed of 2 sub-assemblies :

1 - Screw sub-assembly, harness side

Description ESCC : 340103207B
 Description FR022 : MDM-115288-6916-FR022
 Composed of : 2 Screws + 2 Clips
 Total weight for a pair : 0.88 g max.
 Torque value for screw : 0.28 Nm min. / 0.32 Nm max.

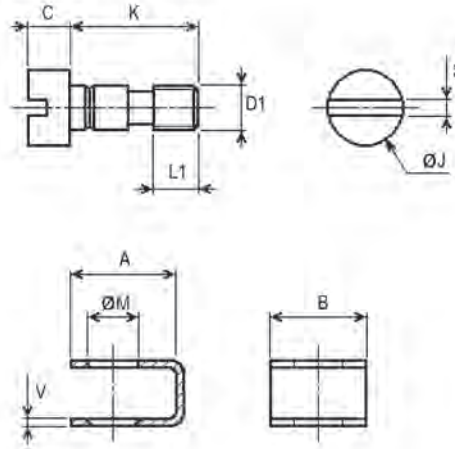

A	4,83 ± 0,25 (.190 ± .010)
B	4,45 max. (.175 max.)
C	2,00 ± 0,15 (.079 ± .006)
D1	2-56 UNC-2A
ØJ	3,68 max. (.145 max.)
K	6,00 ± 0,15 (.236 ± .006)
L1	2,10 + 0,19 / - 0,10 (.083 + .007 / - .004)
ØM	2,35 ± 0,06 (.093 ± .002)
S	0,68 ± 0,10 (.027 ± .004)
V	0,38 ± 0,03 (.015 ± .001)

2 - Screwlock sub-assembly, panel side, rear panel mounting- New version

Panel thickness :	0,80 (.031)	1,20 (.047)	1,60 (.063)
Description ESCC or according to ESCC :	MDM-115366-9223C	MDM-115366-9224C	340103209B
Description FR022 :	MDM-115288-6918-FR022	MDM-115288-6919-FR022	MDM-115288-6920-FR022
Dimension T :	0,73 ± 0,05 (.029 ± .002)	1,13 ± 0,05 (.044 ± .002)	1,53 ± 0,05 (.060 ± .002)

Composed of : 2 Screwlocks + 2 Washers + 2 Nuts
 Total weight for a pair : 1.20 g max.
 Torque value for screwlock, male side : 0.44 Nm min. / 0.48 Nm max.
 Torque value for screwlock, female side : 0.28 Nm min. / 0.32 Nm max.

D1	2-56 UNC-2A
D2	2-56 UNC-2B
E	0,50 Typ (.020 Typ)
F1	3,17 Typ (.125 Typ)
F2	3,80 ± 0,15 (.150 ± .006)
ØG	4,00 ± 0,05 (.157 ± .002)
H	4,58 + 0,04 / - 0,03 (.180 + .002 / - .001)
L	11,60 + 0,20 / - 0,30 (.457 + .008 / - .012)
L2	5,20 min. (.205 min.)
L3	3,20 min. (.126 min.)
N	1,60 ± 0,15 (.063 ± .006)
P	4,20 max. (.165 max.)
ØQ	3,10 ± 0,03 (.122 ± .001)
R	0,70 Typ (.028 Typ)
W	0,30 ± 0,03 (.012 ± .001)
W1	0,50 Typ overall (.020 Typ overall)
ØZ	4,55 ± 0,03 (.179 ± .001)

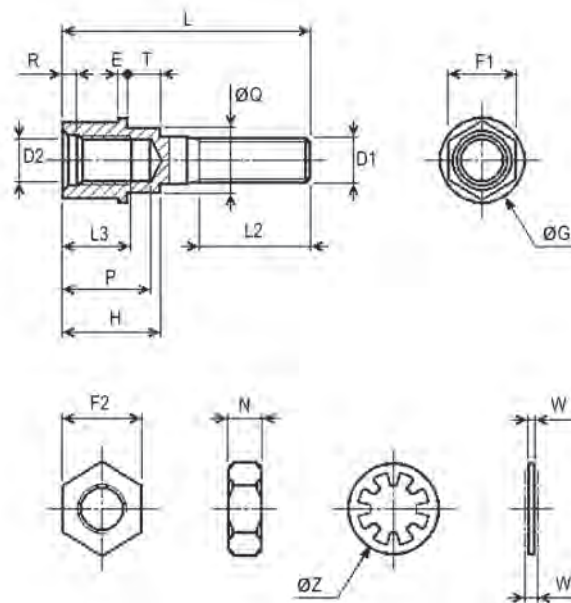

ACCESSORIES

90° mounting brackets

1 - Brackets for shell size 9 to 37

Description ESCC : 340103203B
 Description FR022 : MDM-015-9516-002-FR022
 Composed of : 2 Brackets
 Total weight for a pair : 0.84 g max.

A	3,73 ± 0,13 (.147 ± .005)
B	7,82 max. (.308 max.)
C	4,52 ± 0,13 (.178 ± .005)
øD	2,44 ± 0,13 (.096 ± .005)
D2	2-56 UNC-2B
E	1,47 max. (.058 max.)
F	4,32 max. (.170 max.)
L	6,60 max. (.260 max.)

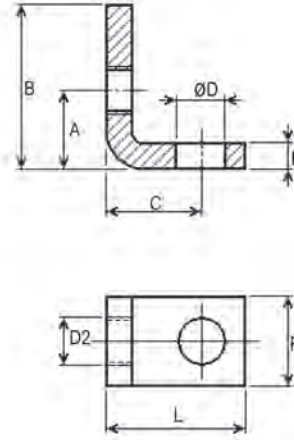

2 - Brackets for shell size 51

Description ESCC : 340103204B
 Description FR022 : MDM-015-9516-003-FR022
 Composed of : 2 Brackets
 Total weight for a pair : 0.90 g max.

A	4,29 ± 0,13 (.169 ± .005)
B	8,89 max. (.350 max.)
C	4,52 ± 0,13 (.178 ± .005)
øD	2,44 ± 0,13 (.096 ± .005)
D2	2-56 UNC-2B
E	1,47 max. (.058 max.)
F	4,32 max. (.170 max.)
L	6,60 max. (.260 max.)

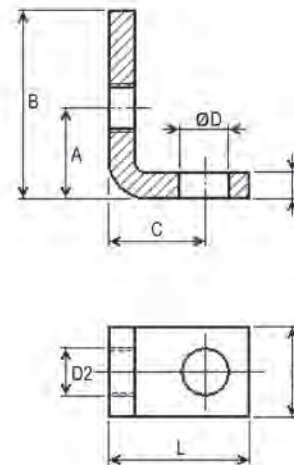

Screwlock assembly for connector savers – old version

1 - Screwlock assembly – Old version

Description ESCC : 340103205B
 Description FR022 : MDM-115288-380-FR022
 Composed of : 2 Screwlocks + 2 Clips
 Total weight for a pair : 2.00 g max.
 Torque value, male side : 0.36 Nm max.
 Torque value, female side : 0.28 Nm max.

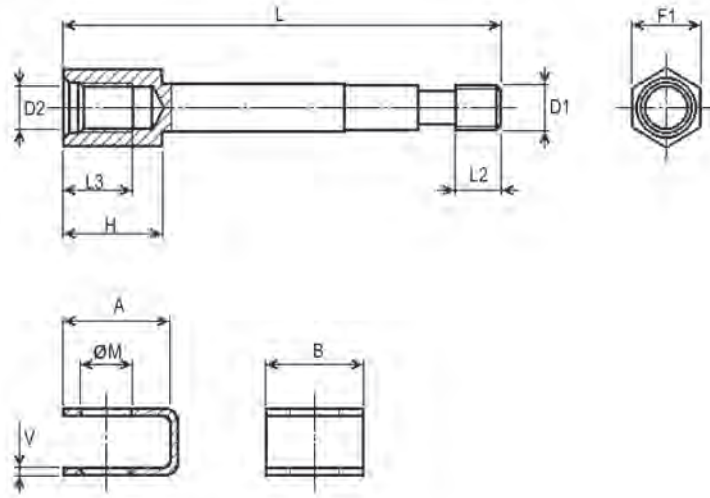

A	4,83 ± 0,25 (.190 ± .010)
B	4,45 max. (.175 max.)
D1	2-56 UNC-2A
D2	2-56 UNC-2B
F1	3,17 Typ (.125 Typ)
H	4,70 max. (.185 max.)
L	20,60 ± 0,25 (.811 ± .010)
L2	2,10 + 0,19 / - 0,10 (.083 + .007 / - .004)
L3	3,50 min. (.138 min.)
ØM	2,35 ± 0,06 (.093 ± .002)
V	0,38 ± 0,03 (.015 ± .001)

2 - Screwlock assembly – New version

Description ESCC : 340103210B
 Description FR022 : MDM-115288-6921-FR022
 Composed of : 2 Screwlocks + 2 Clips
 Total weight for a pair : 1.86 g max.
 Torque value, male side : 0.36 Nm min. / 0.40 Nm max.
 Torque value, female side : 0.28 Nm min. / 0.32 Nm max.

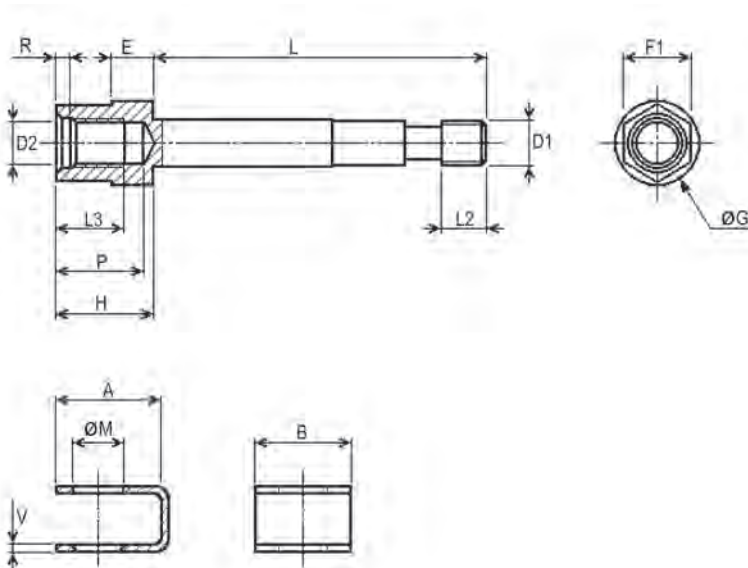

A	4,83 ± 0,25 (.190 ± .010)
B	4,45 max. (.175 max.)
D1	2-56 UNC-2A
D2	2-56 UNC-2B
E	2,00 Typ (.079 Typ)
F1	3,17 Typ (.125 Typ)
ØG	4,00 ± 0,05 (.157 ± .002)
H	4,58 + 0,04 / - 0,03 (.180 + .002 / - .001)
L	15,65 ± 0,10 (.616 ± .004)
L2	2,10 + 0,19 / - 0,10 (.083 + .007 / - .004)
L3	3,20 min. (.126 min.)
ØM	2,35 ± 0,06 (.093 ± .002)
P	4,20 max. (.165 max.)
R	0,70 Typ (.028 Typ)
V	0,38 ± 0,03 (.015 ± .001)

Screwlock for connectors FR136 / FR139 – old version

1 - Screwlock – Old version

Description ESCC : 340103206B
 Description FR022 : MDM-115288-405-FR022
 Composed of : 2 Screwlocks
 Total weight for a pair : 0.60 g max.
 Torque value, male side : 0.44 Nm max.
 Torque value, female side : 0.28 Nm max.

D1	2-56 UNC-2A
D2	2-56 UNC-2B
F1	3,17 Typ (.125 Typ)
H	4,62 max. (.182 max.)
L	9,00 ± 0,25 (.354 ± .010)
L2	2,00 min. (.079 min.)
L3	3,50 min. (.138 min.)

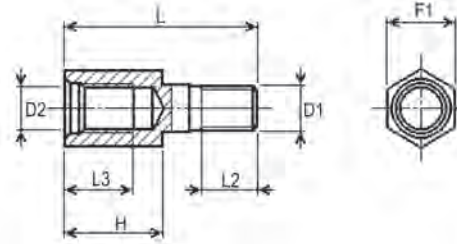

2 - Screwlock – **New version**

Description ESCC : 340103211B
 Description FR022 : MDM-115288-6922-FR022
 Composed of : 2 Screwlocks
 Total weight for a pair : 0.86 g max.
 Torque value, male side : 0.44 Nm min. / 0.48 Nm max.
 Torque value, female side : 0.28 Nm min. / 0.32 Nm max.

D1	2-56 UNC-2A
D2	2-56 UNC-2B
E	2,00 Typ (.079 Typ)
F1	3,17 Typ (.125 Typ)
øG	4,00 ± 0,05 (.157 ± .002)
H	4,58 + 0,04 / - 0,03 (.180 + .002 / - .001)
L	9,00 ± 0,25 (.354 ± .010)
L2	2,00 min. (.079 min.)
L3	3,20 min. (.126 min.)
P	4,20 max. (.165 max.)
R	0,70 Typ (.028 Typ)

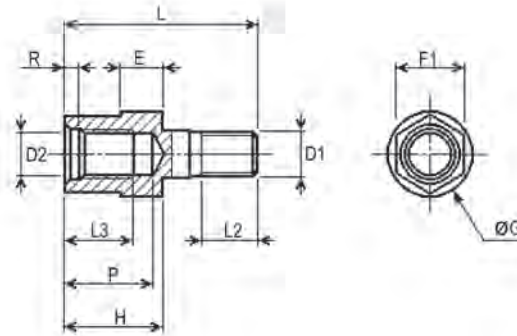

Screwlock for connectors FR136 / FR139, rear panel mounting –old version

1 - Screwlock - Old version

Panel thickness :	0,80 (.031)	1,20 (.047)	1,60 (.063)	2,40 (.094)
Description according to ESCC :	MDM-115366-9203C	MDM-115366-9204C	MDM-115366-9205C	MDM-115366-9206C
Description FR022 :	MDM-115288-602-FR022	MDM-115288-603-FR022	MDM-115288-604-FR022	MDM-115288-605-FR022
Dimension T :	0,67 ± 0,05 (.026 ± .002)	1,07 ± 0,05 (.042 ± .002)	1,47 ± 0,05 (.058 ± .002)	2,27 ± 0,05 (.089 ± .002)

Composed of : 2 Screwlocks
 Total weight for a pair : 0.60 g max.
 Torque value, male side : 0.44 Nm max.
 Torque value, female side : 0.28 Nm max.

D1	2-56 UNC-2A
D2	2-56 UNC-2B
F1	3,17 Typ (.125 Typ)
H	4,62 max. (.182 max.)
L	9,00 ± 0,25 (.354 ± .010)
L2	2,00 min. (.079 min.)
L3	3,50 min. (.138 min.)
øQ	3,10 ± 0,03 (.122 ± .001)

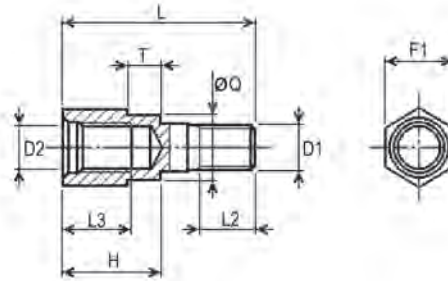

1 - Screwlock - New version

Panel thickness :	0,80 (.031)	1,20 (.047)	1,60 (.063)
Description according to ESCC :	MDM-115366-9225C	MDM-115366-9226C	MDM-115366-9227C
Description FR022 :	MDM-115288-6923-FR022	MDM-115288-6924-FR022	MDM-115288-6925-FR022
Dimension T :	0,73 ± 0,05 (.029 ± .002)	1,13 ± 0,05 (.044 ± .002)	1,53 ± 0,05 (.060 ± .002)

Composed of : 2 Screwlocks
 Total weight for a pair : 0.86 g max.
 Torque value for screwlock, male side : 0.44 Nm min. / 0.48 Nm max.
 Torque value for screwlock, female side : 0.28 Nm min. / 0.32 Nm max.

D1	2-56 UNC-2A
D2	2-56 UNC-2B
E	0,50 Typ (.020 Typ)
F1	3,17 Typ (.125 Typ)
øG	4,00 ± 0,05 (.157 ± .002)
H	4,58 + 0,04 / - 0,03 (.180 + .002 / - .001)
L	9,00 ± 0,25 (.354 ± .010)
L2	2,00 min. (.079 min.)
L3	3,20 min. (.126 min.)
P	4,20 max. (.165 max.)
øQ	3,10 ± 0,03 (.122 ± .001)
R	0,70 Typ (.028 Typ)

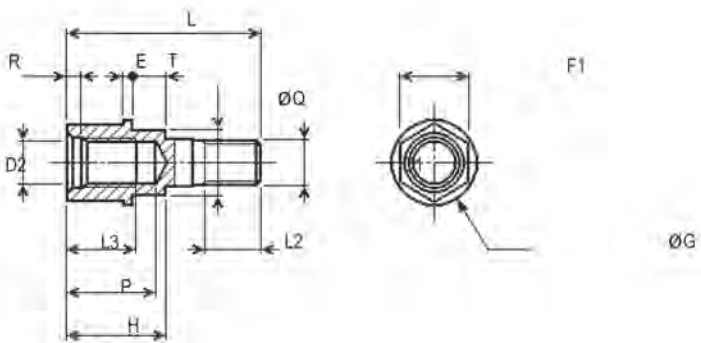

ACCESSORIES

Hardwares compatibility table

No	1	2	3	4	5	6	7	8	9	10	11	12	13	14	15	16	17	18	19	20	21	22	23	24	25	26	27	28	
1		O	O													O	O	O		O									
2	O		O															O		O									
3	O	O														O	O	O											
4					X								X	X	X				X						X	X	X	X	
5				X								X				X	X		X										
6							O	O	O	O	O							O											
7						O		O	O	O	O							O			O	O	O	O					
8						O	O											O											
9						O	O											O											
10						O	O											O											
11						O	O											O											
12					X								X	X	X				X						X	X	X	X	
13				X								X							X										
14				X								X							X										
15				X								X							X										
16	O		O		X																								
17	O		O		X																								
18	O	O	O			O	O	O	O	O	O										O	O	O	O	O				
19				X	X							X	X	X	X											X	X	X	X
20	O	O																O											
21							O											O											
22							O											O											
23							O											O											
24							O											O											
25				X								X							X										
26				X								X							X										
27				X								X							X										
28				X								X							X										

Compatibility code : O : Compatibility between the old references
 X : Compatibility between the new references
 Note : There is no compatibility between the old and the new references

CDRI

Description

The "Customer Design Request Information" document (CDRI) is an C&K Specification, describing a product supplied per specific customer specification.

For CDRI : Consult factory .

Content

The CDRI document includes all the necessary data for :

- Customer use : characteristics of the product to be inserted into the Customer equipment
- C&K use : informations for the manufacturing of the product

The main informations are the following :

- Detailed description of the product
- Eventual applicable specifications or other documents
- Eventual drawings (Customer or C&K)
- Detailed amendments to the reference product (dimensions, piece parts, materials, cables)
- Detailed amendments to the manufacturing process (assembling, controls, marking, packaging, documentation)
- Quality level :
 - ESA : Supply in accordance with the requirements of the ESCC Generic Specification n° 3401
 - FR022 : Supply in accordance with the requirements of the C&K Specification CS FR022
 - Other if applicable
- Allocated Descriptions and Part Numbers
- Allocated CDRI number

Process

- Identification of the Customer request (specification, drawing, technical note)
- Analysis and feasibility study
- Proposal of the best solution, with eventual modifications
- Finalization of the Customer request
- Eventual prototype
- Commercial offer
- Finalization of the CDRI document

Technical issues specific to the MDM Connectors

The following parameters can be used for the amendments to the MDM Connectors described in this Catalogue.

Other parameters shall be clearly described in the customer drawings (or specifications).

Terminations.

- Solder Cup terminations
- Other PCB termination lengths (Customer drawing)

Cables.

- Other cable lengths (Customer drawing)
- Other ESCC 3901002 or 3901013 cable references (Customer drawing)
- Other ESCC cable references (Customer drawing)
- Other MIL-W-16878/4 cable references (Customer drawing)
- Other cable specifications (Customer drawing)
- Cable size AWG 30 (Customer drawing)
- Shielded cables (Customer drawing)
- Multicore cables, 4 cores max. per cable (Customer drawing)
- Coaxial cables type 50 CIS or RG178 (Customer drawing)

Harnessing.

- Shielded cables, with conductor wired to a contact and shield wired to an adjacent contact or to an external cable (Customer drawing)
- Coaxial cables, with conductor wired to a contact and shield wired to an adjacent contact or to an external cable (Customer drawing)
- Protection of the specific wiring areas by thermo-shrinkable kynar tubes (Customer drawing)
- Protection of the specific wiring areas by rear potting (details below) (Customer drawing)
- Wiring of 2 or more connectors to the same harness network (Customer drawing)

Rear potting.

- Standard : 10,00 mm (.394) extension of the rear shell section length by a volume of epoxy, molded around the cable wiring area
- Other rear potting dimensions (Customer drawing)

Hardware.

- Other hardware) :
 - ▣ Reference K (Jackscrew, standard)
 - ▣ Reference L (Jackscrew, low profile)
 - ▣ Reference P (Jackpost, front panel mounting)
 - ▣ Reference M2 (Allen head Jackscrew assy low profile, MIL-DTL-83513/5-02)
 - ▣ Reference M3 (Allen head Jackscrew assy high profile, MIL-DTL-83513/5-03)
 - ▣ Reference M5 (Slotted head Jackscrew assy low profile, MIL-DTL-83513/5-05)
 - ▣ Reference M6 (Slotted head Jackscrew assy high profile, MIL-DTL-83513/5-06)
 - ▣ Reference M7 (Jackpost assy, MIL-DTL-83513/5-07)
- Specific hardware (Customer drawing)

Backshells.

- Specific backshells (Customer drawing)

Others.

- Shell size 100
- Combination arrangements 7C2, 7P2, 24C4, 24P4
- Other solutions on special request (Customer drawing)